



Primo Cappuccino™ 4/5 Station Dispensing System



Style Varies - PCGT4 Shown

READ AND SAVE THESE INSTRUCTIONS

NOTICE TO INSTALLER: Please leave this booklet with the machine.

Key Features/Specifications/System Requirements..... FS41

Important Safeguards..... IS2

Installation Instructions (General).....II2

Installation Instructions (Leveling, Water Supply, Electrical).....II22

Operating InstructionsOI33

Cleaning Instructions (General)..... CI19

Cleaning Instructions (Whipper Plate Assembly) CI20

Programming Guide PG12

Rough-In Drawing..... RD47

Illustrated Parts/Recommended Parts (Main Chassis)..... IP78

Illustrated Parts/Recommended Parts (Tank Assembly, Standard) IP76

Illustrated Parts/Recommended Parts (Tank Assembly, Dual Voltage) IP77

Illustrated Parts/Recommended Parts (Tank Assembly, PCGT5 w/Hot Water Faucet)..... IP79

Illustrated Parts/Recommended Parts (Tank Assembly, Export) IP80

Electrical Schematics ES85

Troubleshooting Guide (General).....TG23

Troubleshooting Guide (Dump Valve Calibration).....TG24

Error CodesEC7

Product Warranty.....PW1

Contact Information

Wilbur Curtis Co., Inc.

6913 Acco Street | Montebello, CA 90640 US
 Phone: 323-837-2300 | Toll Free: 800-421-6150
 Email: csrcassistance@wilburcurtis.com | Web: www.wilburcurtis.com

For the latest specifications and information go to www.wilburcurtis.com
 Toll Free: 800-995-0417 | Monday - Friday 5:30 A.M. - 4:00 P.M. PT
 Email: techsupport@wilburcurtis.com

Due to continued product improvement, the products illustrated/photographed in this guide may vary slightly from the actual product.

Key Features

- G3 Digital Control Module - Provides precise control over all critical blending and dispensing functions.
- Factory Pre-Set - For out-of-the-box operation.
- LCD Digital Display - Extra bright and easy to use.
- Scroll-Through Precision Programming - Adjust powder flow in 5% increments and water temperature from 0°F to 204°F (96°C) to create the perfect hot or cold beverage.

Specifications (Selected Models)

Electrical Supply Requirements

MODEL #	DESCRIPTION	PHASE	VOLTS	AMPS	HEATING CONFIG	WIRE	WATTS	HERTZ	GAL/HR
PCGT4	4 Station	1 PH	120 V	15.0 A	1 x 1600 W	2W + G	1800 W	50/60 Hz	5.3
PCGT4300	4 Station with lift door	1 PH	120 V	15.0 A	1 x 1600 W	2W + G	1800 W	50/60 Hz	5.3
PCGT5	5 Station, dual voltage	1 PH	120 V	15.0 A	1 x 1600 W	2W + G	1800 W	50/60 Hz	5.3
PCGT5DV	5 Station, dual voltage	1 PH	120/220 V	15.0/14.5 A	2 x 1600 W	2W/3W + G	1800/3000 W	50/60 Hz	5.3/10.7
PCGT5300	5 Station with lift door	1 PH	120 V	15.0 A	1 x 1600 W	2W + G	1800 W	50/60 Hz	5.3
PCGT5800	5 Station with lift door	1 PH	120 V	15.0 A	1 x 1600 W	2W + G	1800 W	50/60 Hz	5.3
EXPORT									
PCGT4E	4 Station, export	1 PH	230 V	17.6 A	1 x 3500 W	2W + G	4044 W	50/60 Hz	11.0

Dimensions

Water Supply Requirements

MODEL #	HEIGHT	WIDTH	DEPTH	SHIP WEIGHT	SHIP CUBE	WATER CONNECTOR	WATER PRESSURE	MIN. FLOW RATE
PCGT4	34.78"	20.86"	24.50"	160.0 lbs	22.92 cu ft	1/4" flare	20 - 90 psi	1.0 gpm
PCGT4300	34.78"	20.86"	24.50"	160.0 lbs	22.92 cu ft	1/4" flare	20 - 90 psi	1.0 gpm
PCGT5	34.78"	20.86"	24.50"	160.0 lbs	22.92 cu ft	1/4" flare	20 - 90 psi	1.0 gpm
PCGT5DV	34.78"	20.86"	24.50"	160.0 lbs	22.92 cu ft	1/4" flare	20 - 90 psi	1.0 gpm
PCGT5300	34.78"	20.86"	24.50"	160.0 lbs	22.92 cu ft	1/4" flare	20 - 90 psi	1.0 gpm
PCGT5800	34.78"	20.86"	24.50"	160.0 lbs	22.92 cu ft	1/4" flare	20 - 90 psi	1.0 gpm
EXPORT								
PCGT4E	34.78"	20.86"	24.50"	160.0 lbs	22.92 cu ft	1/4" flare	20 - 90 psi	1.0 gpm

Following are the factory default settings for the Primo Cappuccino™ dispenser:

- Water Temperature = 190°F (88°C)
- Powder Ratio = 60%

Symbols



This is the safety alert symbol. It is used to alert you to potential physical injury hazards. Obey all safety messages that follow this symbol to avoid possible injury or death.



DANGER - Indicates a hazardous situation which, if not avoided, will result in death or serious injury.



WARNING - Indicates a hazardous situation which, if not avoided, could result in death or serious injury.



CAUTION - Indicates a hazardous situation which, if not avoided, could result in minor or moderate injury.



NOTICE - Indicates a situation which, if not avoided, could result in property damage.



IMPORTANT - Provides information and tips for proper operation.



SANITATION REQUIREMENTS



WARNING - This product can expose you to chemicals including Acrylamide and Bisphenol A (BPA), which are known to the State of California to cause cancer and birth defects or other reproductive harm. For more information visit www.P65Warnings.ca.gov.

Important Safeguards/Conventions



WARNING:

- Make sure that this appliance is installed and grounded according to the INSTALLATION INSTRUCTIONS by qualified personnel before attempting to use it. Failure to follow the INSTALLATION INSTRUCTIONS could result in personal injury or void the warranty.
- This appliance is designed for commercial use. Any service other than cleaning and preventive maintenance should be performed by an authorized Wilbur Curtis service technician.
- To reduce the risk of fire or electric shock, DO NOT open the service panels. There are no user serviceable parts inside.
- Keep hands, arms and other items away from hot surfaces of the unit during operation.
- Clean the appliance and any dispensers completely before using them for the first time according to the CLEANING INSTRUCTIONS. Clean them regularly as instructed in the CLEANING INSTRUCTIONS.
- Use this appliance only for its intended use, brewing/dispensing hot and/or cold beverages/water.
- This appliance is not intended for use by persons (including children) with reduced physical, sensory or mental capabilities or lack of experience and knowledge, unless they have been given supervision or instruction concerning use of the appliance by a person responsible for their safety. Children should be supervised to ensure that they do not play with the appliance.
- Avoid spillage onto the power (mains) connector.

CE Requirements

- This appliance must be installed in locations where it can be overseen by trained personnel.
- For proper operation, this appliance must be installed where the temperature is between 5°C to 35°C.
- Appliance shall not be tilted more than 10° for safe operation.
- An electrician must provide electrical service as specified in conformance with all local and national codes. For safe use, an all-pole disconnection must be incorporated into the fixed wiring in accordance with the wiring rules outlined in clause 7.12.2 of IEC 6.335-1 for meeting the minimum electrical safety of this standard.
- This appliance must not be cleaned by water jet.
- This appliance can be used by persons aged from 18 years and above if they have been given supervision or instruction concerning use of the appliance in a safe way and if they understand the hazards involved.
- Keep the appliance and its cord out of reach of children aged less than 18 years.
- Appliances can be used by persons 18 years and above with reduced physical, sensory or mental capabilities or lack of experience and knowledge if they have been given supervision or instruction concerning use of the appliance in a safe way and understand the hazards involved.
- Children under the age of 18 years should be supervised to ensure they do not play with the appliance.
- If the power cord is ever damaged, it must be replaced by the manufacturer or authorized service personnel with a special cord available from the manufacturer or its authorized service personnel in order to avoid a hazard.
- Machine must not be immersed for cleaning.
- Cleaning and user maintenance shall not be made by children unless they are older than 18 years and supervised.
- This appliance is intended to be used in household and similar applications such as:
 - staff kitchen areas in shops, offices and other working environments;
 - by clients in hotels, motels and other residential type environments;
 - bed and breakfast type environments.
- This appliance not intended to be used in applications such as:
 - farm houses
- Access to the service areas permitted by Authorized Service personnel only.
- The A-Weighted sound pressure level is below 70 dBA.



WARNING: Installation is to be performed only by a qualified installer.



WARNING: Improper electrical connection may result in an electric shock hazard. This brewer must be properly grounded.



NOTICE: DO NOT connect this brewer to a hot water supply. The water inlet valve is not rated for hot water. Do not exceed the maximum water pressure stated in the *SPECIFICATIONS* section.



IMPORTANT: Observe all governing codes and ordinances.

Installation Instructions

Installation Requirements

- A secure surface capable of supporting the weight of the appliance.
- For units without an attached cord set: Appropriately sized, UL listed, grounding type power cable to meet the electrical specifications for the appliance. If you have questions about the correct cable size and length, consult a qualified installer. If the appliance will be hard wired to a junction box, the power cable must be long enough so that the unit can be moved for cleaning underneath.
- A grounded electrical connection to an electrical circuit that meets the electrical specifications of the appliance (see *SPECIFICATIONS*). The circuit must be protected by the appropriate sized circuit breaker. If you are not certain that the existing circuit meets the requirements for your unit, consult a licensed electrician.
- A water filtration system is required to maintain trouble-free operation. Wilbur Curtis Co., Inc. recommends a Wilbur Curtis approved water filter. Visit www.wilburcurtis.com to see the full line of Wilbur Curtis approved water filters.
- Potable water supply line connection from the water filter capable of supplying the minimum flow rate required by the specifications. The water supply line must be able to connect to the flare fitting on the back of the unit. See the *SPECIFICATIONS* section for the correct size. The water line should also be capable of being controlled by a shut off valve. Do not connect the water line to a saddle valve or needle valve.



NSF International requires the following water connection:

- 1 A quick disconnect or additional coiled tubing (at least two times the depth of the appliance) is required so that it can be moved for cleaning underneath.
- 2 This equipment is to be installed with adequate back-flow protection to comply with applicable federal, state and local codes.
- 3 Water pipe connections and fixtures directly connected to a potable water supply shall be sized, installed and maintained in accordance with federal, state and local codes.

The International Plumbing Code of the International Code Council and the Food and Drug Administration (FDA) Food Code manual, direct that this equipment must be installed with adequate back-flow prevention in compliance with federal, state and local codes. For units installed outside of the U.S.A., make sure that the installation is in compliance with the applicable plumbing/sanitation code for your area.

Installation

Leveling



WARNING: Use the leveling legs to level the dispenser only. Do not use them to adjust dispenser height. Do not extend them higher than necessary.

- 1 Position the dispenser on the counter top. Level it left to right and front to back by turning the bottom of the legs.

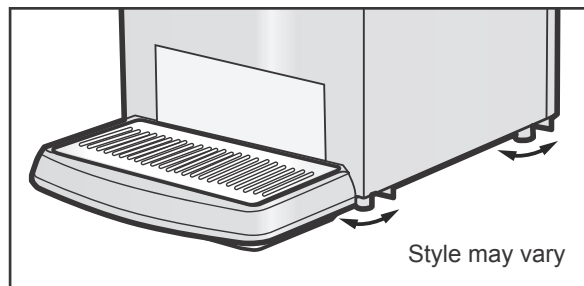

Connect the Water Supply

- 2 Flush the water supply line prior to installation to purge air and debris from the water filter and tubing.
- 3 Connect the water supply line to the flare fitting on the back of the unit. Leave the water supply valve closed until power is connected.

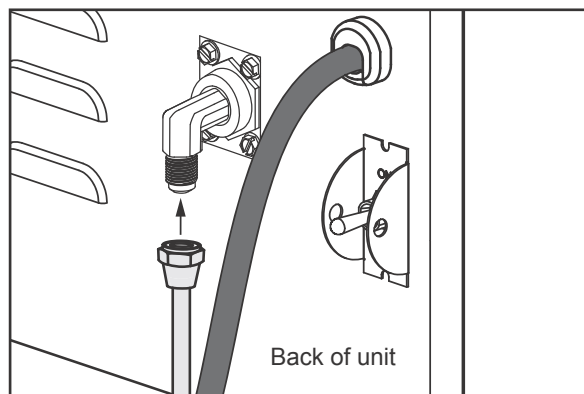

Connect the Wiring - Dual Voltage Units to be Operated 220-240 Volts Only



WARNING: Turn off power to the junction box at the circuit breaker panel before connecting the power cable to the dispenser. Lock out and tag the circuit breaker.

- 4 Remove the top cover and the left side panel to expose the terminal block.
- 5 Disconnect and cap the jumper wire between the “C” and “N” terminals on the terminal block.
- 6 Loosen the strain relief on the back panel.
- 7 Disconnect the 120 Volt power cable from the terminal block and pull the cable out through the back.
- 8 Feed the end of the 220-240 Volt power cable through the strain relief, into the unit.
- 9 Connect the wires on the power cable to the terminal block inside.
- 10 Tighten the strain relief and replace the side and top panels.
- 11 Connect the power cable wires to the terminals in the junction box. See the *ELECTRICAL SCHEMATIC* for the power supply requirements.

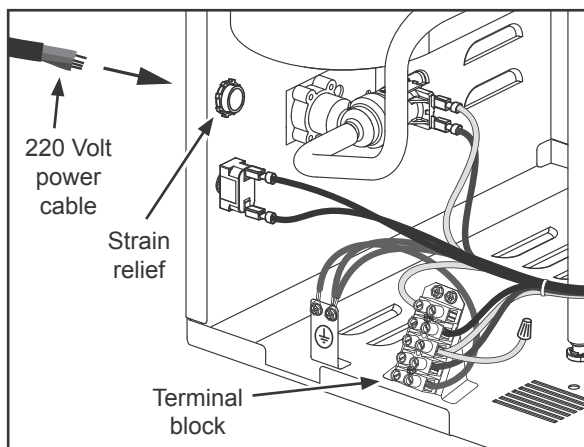
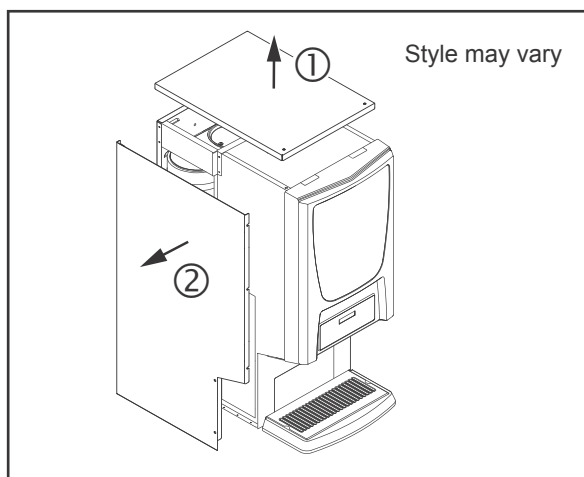

Connect the Power Cable - 120 Volt Units



WARNING: Connect the power cord to the appropriate type and size electrical outlet. If the electrical outlet is not compatible with the power cord, have it upgraded by a licensed electrician. Do not modify the power plug. Do not use an extension cord. Do not use a power cord/plug that is damaged.

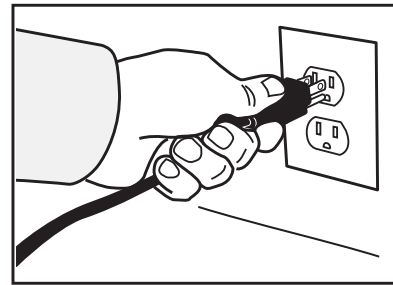

- 12 Connect the power cord to the appropriate type of electrical outlet.

Power Up the Unit

- 13 Turn on the water supply valve.
- 14 Make sure that the circuit breaker supplying power to the dispenser is on.
- 15 Turn the toggle switch on the back of the dispenser to the ON position. The water tank will start to fill. While the tank is filling, inspect the water supply line for leaks.
- 16 When the water level in the tank rises to the correct volume, the heating element(s) will turn on automatically. Depending on the incoming water temperature and the electrical specifications, the water tank typically requires 1 hour to reach the factory set operating temperature. When the water has heated, "Ready to Dispense" should be on the display.
- 17 If the unit is equipped with a hot water faucet, before using the unit for the first time, dispense 12 ounces of hot water from the hot water faucet to help purge air from the tubing inside the unit.
- 18 Dispense at least 12 ounces from each spout, to purge any remaining air from the tubing. See **OPERATING INSTRUCTIONS**. During initial dispensing, and whenever the filter is replaced, you may hear the sounds of air being purged from the filter, tubing and water tank.

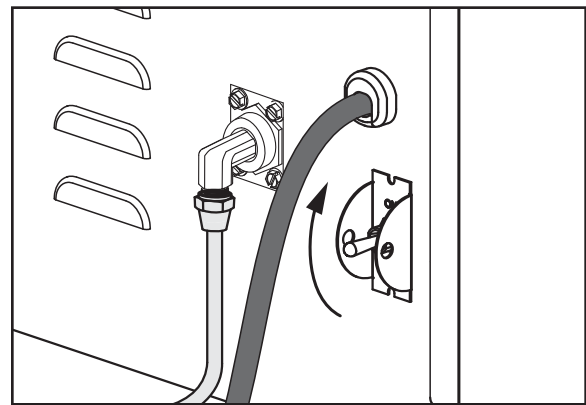

Dispensing

⚠ WARNING - TO AVOID SCALDING, AVOID SPLASHING. Keep body parts clear of the spout during dispensing. Do not remove the cup during dispensing.

The G3 dispenser is factory preset for optimal performance.

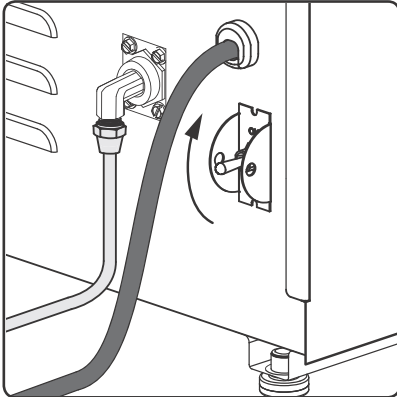

1 The unit should be ON. Confirm this at the rear toggle switch. "Ready to Dispense" should be on the display.

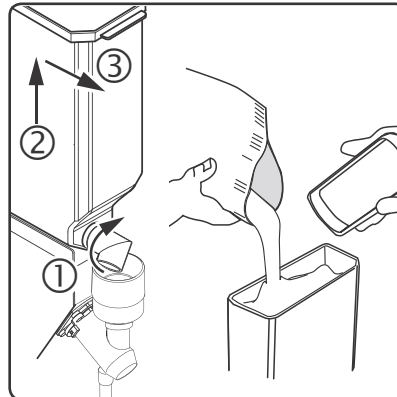

2 Open the front panel. On some models the panel swings to the right, on others, the panel swings up. Turn the elbow on each canister to be filled upward, then lift each canister up and out. Fill with powdered cappuccino product.

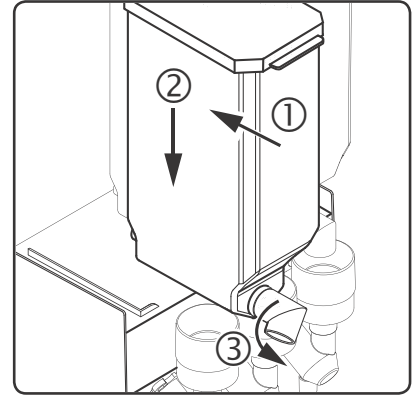

3 Reinstall each canister in the same spot it was removed from. Properly mate the gear socket on the back of each canister with the gear inside the dispenser. Turn the canister elbows downward and close the door.

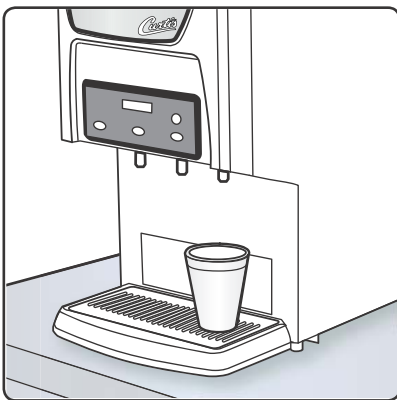

4 Place a cup under the spout for the desired flavor. If the dispenser is set for iced coffee, fill the cup with ice first.



Preset Dispense Models:

5A Push and release the dispensing button for the desired flavor and cup size. Remove the cup when product stops flowing.



Manual Dispense Models:

5B Push and hold the dispensing button for the desired flavor. Release the button when the cup is 3/4 full. Remove the cup when product stops flowing.

Spout Cleaning - Every 3 or 4 Hours

- 1 Make sure power is ON.
- 2 Place a container under the dispense spout to catch the rinse water.
- 3 Rinse each flavor by pressing and holding the WASH button, while at the same time pressing one of the PUSH dispensing buttons on the control panel. Continue holding the WASH button until the water running from the spout runs clear.

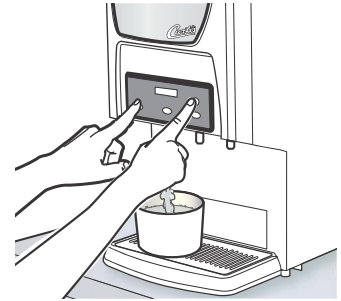

Cleaning the Exterior - Daily



WARNING: HOT SURFACES - To avoid injury, allow the dispenser to cool before cleaning.



WARNING: DO NOT immerse the dispenser in water or any other liquid.



NOTICE - Do not use cleaning liquids, compounds or powders containing chlorine (bleach) or corrosives. These products promote corrosion and will damage the finishes. **USE OF THESE PRODUCTS WILL VOID THE WARRANTY.**

The dispenser should be OFF. Turn the brewer off by flipping the rear toggle switch to the OFF position.

- 1 Wipe the exterior dispenser surfaces with a damp cloth to remove spills and debris.
- 2 Lift the drip tray up to remove. Remove the louvered grill from the drip tray, then wash out the tray with the detergent solution. Wash the louvered grill, then rinse both pieces with water and dry.
- 3 Wipe and clean the dispensing area with the detergent solution, then reinstall the drip tray.

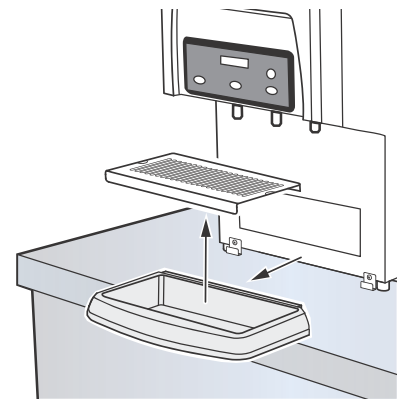

Cleaning The Whipper Plate Assembly CAFEPCC and PCGT Series - Weekly or As Needed

The dispenser should be OFF. Turn the dispenser off by turning the rear toggle switch to the OFF position.

- 1 Remove the dispensing spout from the whipper chamber. Clean the inside using a narrow brush.
- 2 Pull the upper mixing cup forward and twist it up and to the left to separate it from the lower mixing cup.
- 3 To remove the lower mixing cup, pull it up and forward to free it from the hot water inlet.
- 4 Take hold of the whipper chamber. Turn it clock-wise to free it from the mounting plate.
- 5 Pull the whipper propeller off of the motor shaft.
- 6 Wash, rinse, sanitize and air dry the whipper assembly parts using the 3-sink method. Wash in a mild solution of warm water and dishwashing detergent, rinse in warm clean water and sanitize in a commercial sanitizer suitable for food grade applications. Sanitize according to the directions on the package. Air dry all parts.
- 7 Clean the motor shaft with a cloth and mild detergent before removing the mounting plate.
- 8 Twist the mounting plate clockwise and pull it off of the motor shaft.
IMPORTANT - Do not remove the mounting pillars to remove the mounting plate.
- 9 Clean the area behind the mounting plate and the water inlet fitting.
- 10 Lubricate the center seal of the mounting plate with food grade lubricant before reinstalling (See Figure 3).
- 11 Reassemble the cleaned whipper assembly parts into the unit in reverse order.

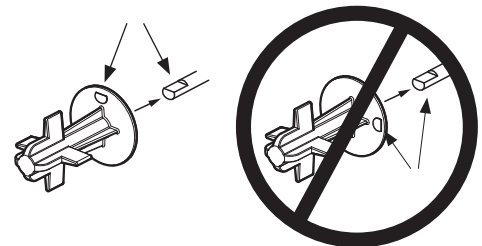
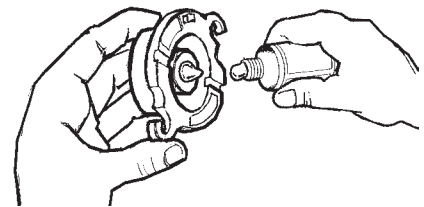
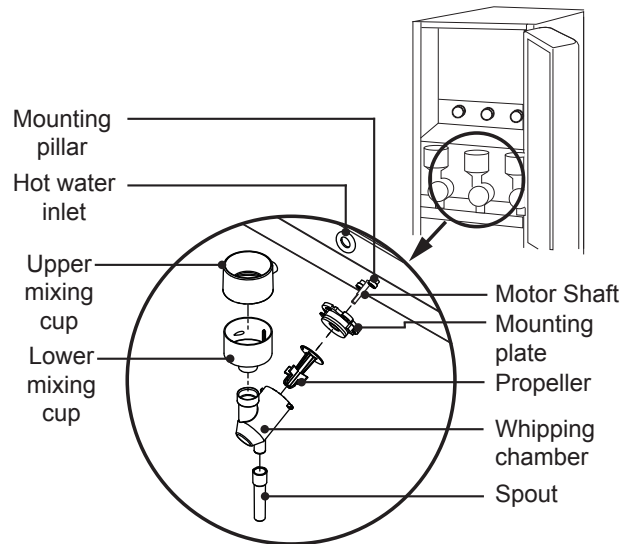

CAUTION: When replacing the propeller, line up the "D" shaped mark on the propeller with the "D" shape on the motor shaft. Failure to line up the propeller properly will cause it to fuse with the shaft. This condition is not covered under the warranty.

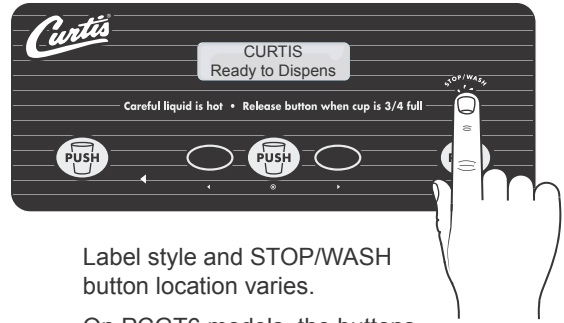
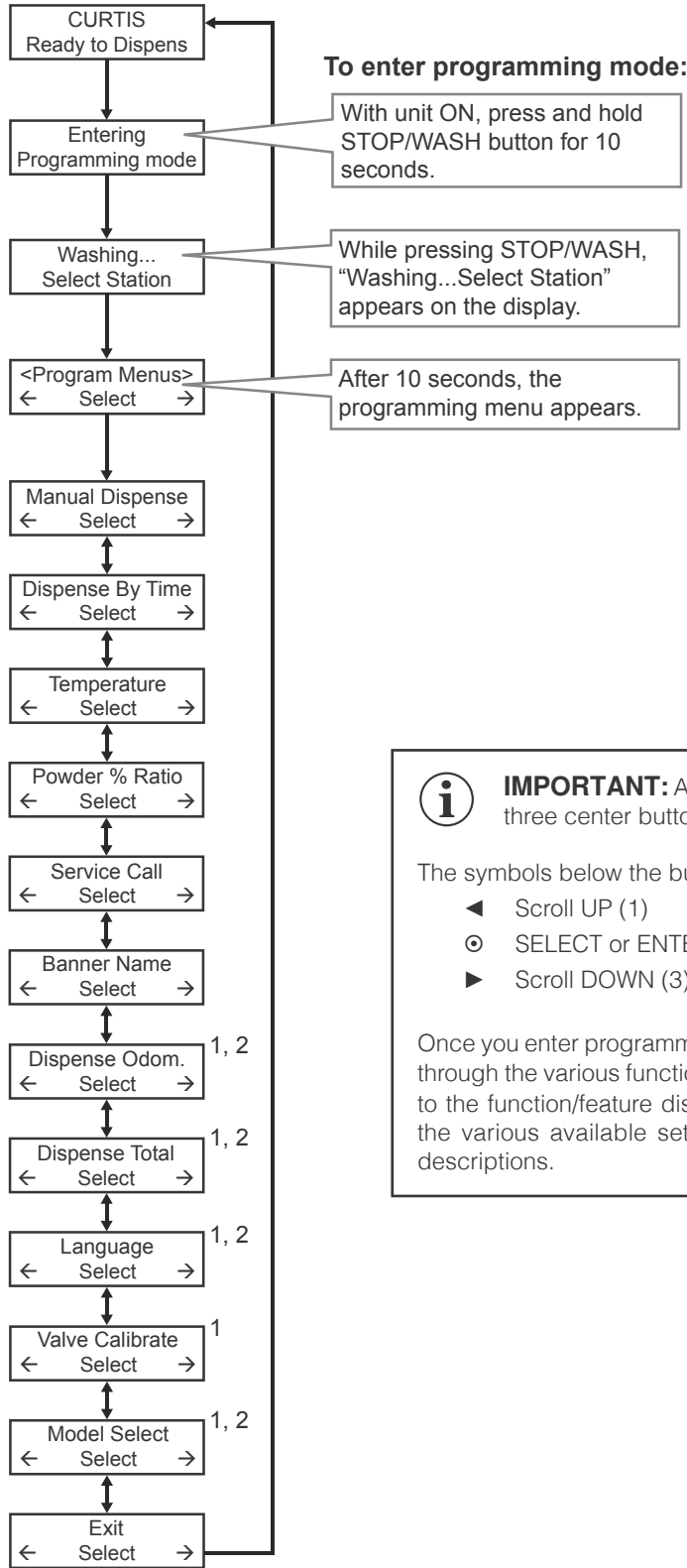

Label style and STOP/WASH button location varies.
On PCGT6 models, the buttons are located inside the front door.

i IMPORTANT: All programming functions are performed with the three center buttons.

The symbols below the buttons are:

- ◀ Scroll UP (1)
- ⊙ SELECT or ENTER to save new parameter (2)
- ▶ Scroll DOWN (3)

Once you enter programming mode, press ◀ or ▶ to scroll UP or DOWN through the various functions/features. Press ⊙ (Select) to make changes to the function/feature displayed. Then press ◀ or ▶ to scroll through the various available settings. See *Programming Options* for detailed descriptions.

¹ Not present on Pre-Set Dispense models
² Not present on PCGT6 series models.

Programming Options

See the first page of the *PROGRAMMING GUIDE* for instructions on how to access the programming menu. To exit programming mode, press ► until EXIT appears on the display, then press Ⓞ.

Manual Dispense - All stations are set to Manual Dispense mode at the factory (except on Pre-Set Dispense models). The Manual Dispense programming option is used to change stations that are set to Dispense By Time (see below) to Manual Dispense mode. Press Ⓞ to access, then press the PUSH button for the station to be set to Manual Dispense. "Saving Complete!" will appear on the display, then return to the programming menu. Repeat the process to set other stations, if desired, or press ► to go to the next menu.

Dispense by Time - (default on Pre-Set Dispense Models) sets the unit to dispense the amount of product by time rather than holding the button until the desired amount is dispensed. Place a cup below the spout for the desired station. Press Ⓞ to access. Press the PUSH button for the station to be set to Dispense By Time (Manual Dispense will be disabled for that station). The display will read "To Begin Push PUSH". Push the desired PUSH button. Hot water will start to dispense and the screen will display "To Finish Push PUSH". When the desired volume is reached push the button again. The display will go back to the programming menu. Repeat the process to set other stations if desired, or press ► to go to the next menu.

Default Settings Time Dispense Settings Preset Dispense Models	
Cup Size	Time Setting
LARGE	25.5 Seconds
MEDIUM	16.5 Seconds
SMALL	12.5 Seconds

Temperature - sets the temperature of the water held in the water tank. The range is 80°F to 204°F (27°C to 96°C). The recommended temperature for iced coffee units is 96°F. The recommended temperature for all other units is 190°F (88°C). Press Ⓞ to access. Press ◀ or ▶ to choose the desired temperature. Then press Ⓞ to set and exit. Press ► to continue to the next menu.

Powder % Ratio - sets the ratio of product powder dispensed. The higher the powder ratio, the richer the product dispensed. The factory default setting is 60%. The range is from 0% (hot water) to 100% (7 grams per 10%). Press Ⓞ to access. Press the PUSH button for the desired station. Press ◀ or ▶ to increase or decrease the ratio, then press Ⓞ to set and exit. Press ► to continue to the next menu.

% Ratio	Grams*
10%	7 gm
20%	14 gm
30%	21 gm
40%	28 gm
50%	35 gm
60%	42 gm
70%	49 gm
80%	56 gm
90%	63 gm
100%	70 gm

*Approximate

Service Call - sets the service phone number that appears on the display when the unit detects a SENSOR ERROR or WATER LEVEL ERROR. Press Ⓞ to access. Press ◀ or ▶ to choose the number to be changed. Then press Ⓞ repeatedly to change the number value. Press ◀ or ▶ to choose the next number to change or choose ex and press Ⓞ to exit. Repeat the process to set other stations, or press ► to go to the next menu.

Banner Name - changes the banner name that appears on the display (the factory default is **CURTIS**). No banner name appears when all blanks are entered. Press Ⓞ to access. Press ◀ or ▶ to choose the letter to change. Then press Ⓞ repeatedly to change the letter. Press ◀ or ▶ to choose the next number to change or choose ex and press Ⓞ to exit. Press ► to continue to the next menu.

Dispense Odom^{1, 2} - displays the total dispense cycles since the odometer was last reset. Press Ⓞ to access. Press ◀ to exit or Ⓞ reset and exit. Press ► to continue to the next menu.

¹ Not present on Pre-Set Dispense models

² Not present on PCGT6 series models

Programming Options (cont.)

Dispense Total^{1, 2} - when accessed, displays the total dispense cycles on the unit. It cannot be reset. The display returns to the previous screen automatically after a few seconds. Press ► to continue to the next menu.

Language^{1, 2} - changes the language that appears on the display (the factory default is English). Press ⊙ to access. Press ◀ or ▶ to choose the desired setting, then press ⊙ to exit. Press ► to continue to the next menu.

Valve Calibrate¹ - pours water (only) from the spout, for 10 seconds to allow the dump valves to be calibrated. See *Dump Valve Calibration* in the *Troubleshooting Section* for the complete dump valve calibration procedure. Press ⊙ to access. The bottom portion of the display will read "Select Station". Place an empty measuring cup under the dispensing spout for the valve to be calibrated. Press the PUSH button above the cup. Water will dispense for 10 seconds. Press ⊙ to measure flow rate for a different valve, or press ► to continue to the next menu.

Model Select^{1, 2} - changes the model number. The unit must be set to the proper model number for proper operation. Press ⊙ to access. Press ◀ or ▶ until the model number matching the model number label on the unit appears, then press ⊙ to exit. Press ► to continue to the next menu.

¹ Not present on Pre-Set Dispense models

² Not present on PCGT6 series models

PCGT4/5

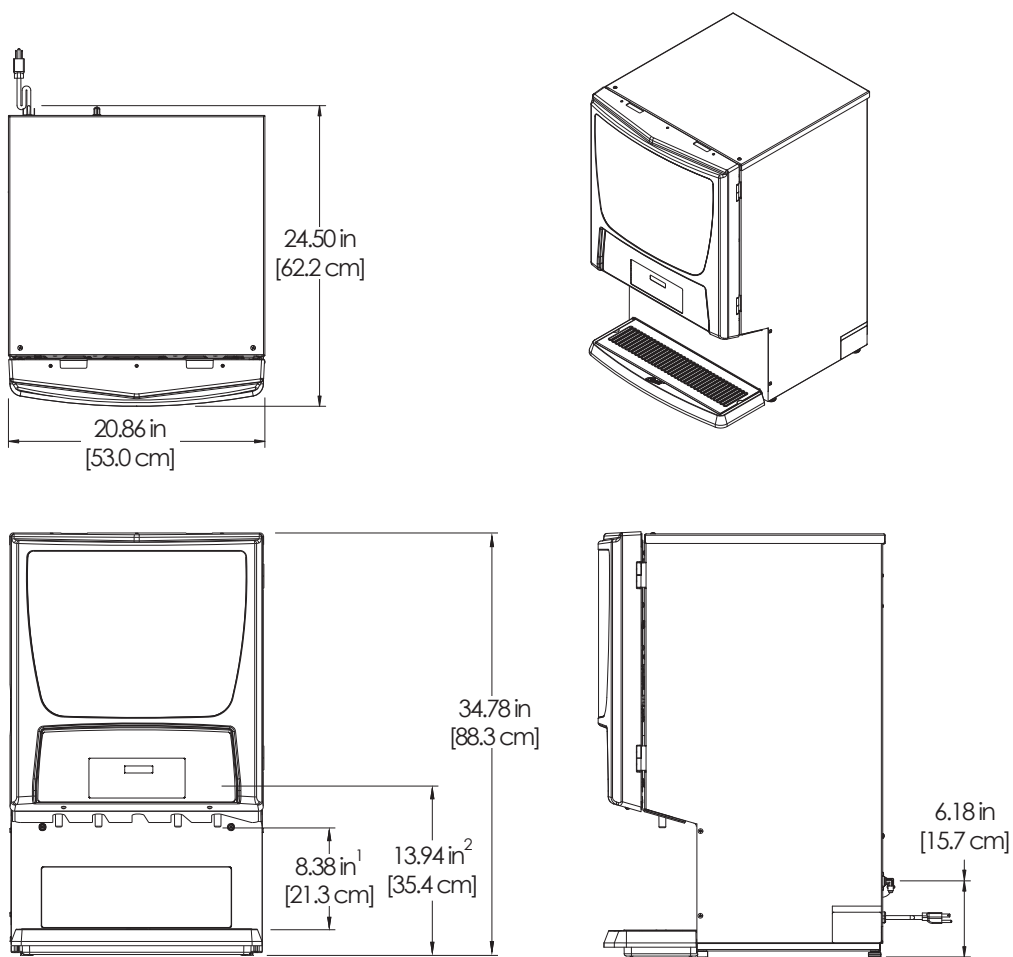

¹CUP CLEARANCE
²DISPENCE BUTTON HEIGHT

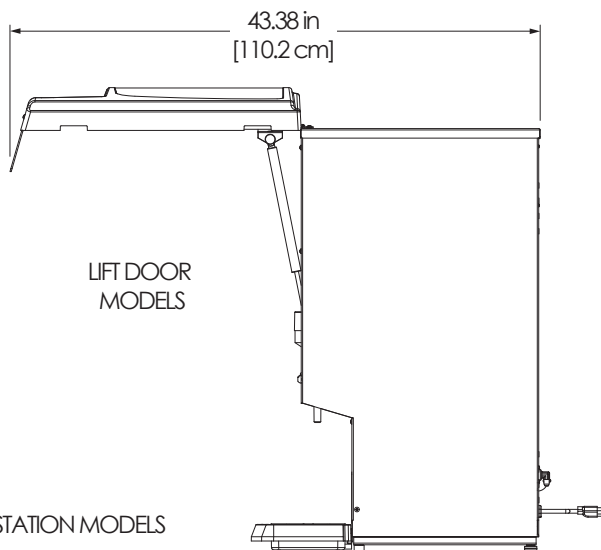

DIMENSIONS APPLY TO ALL 4 AND 5 STATION MODELS

PCGT4/5 - Door Assemblies - Exploded View

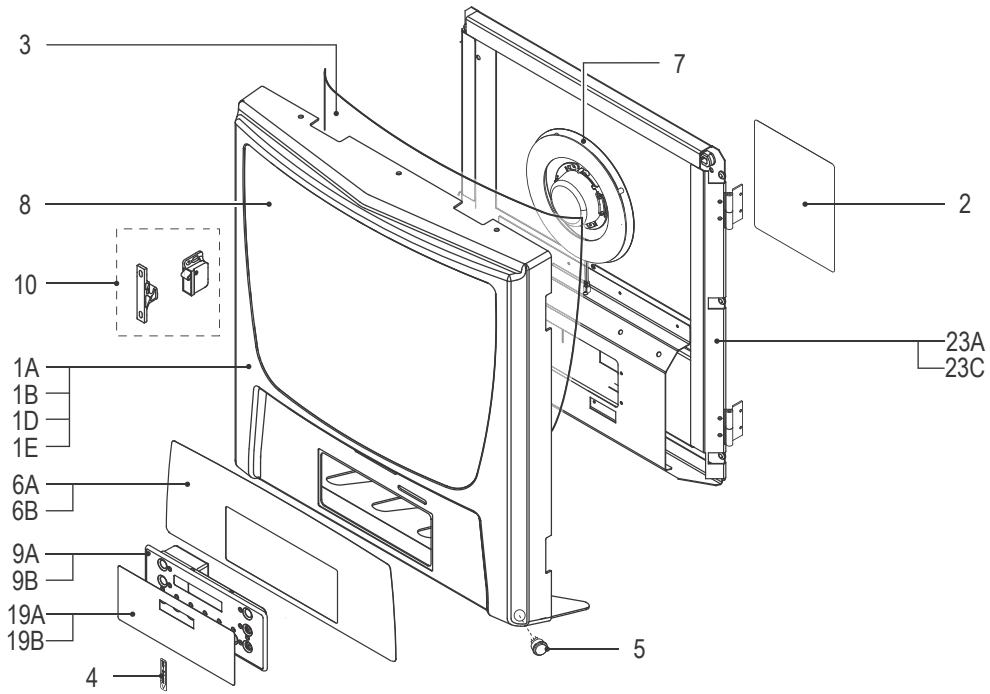

PCGT4, PCGT4E,
PCGT5, PCGT5DV, PCGT5800

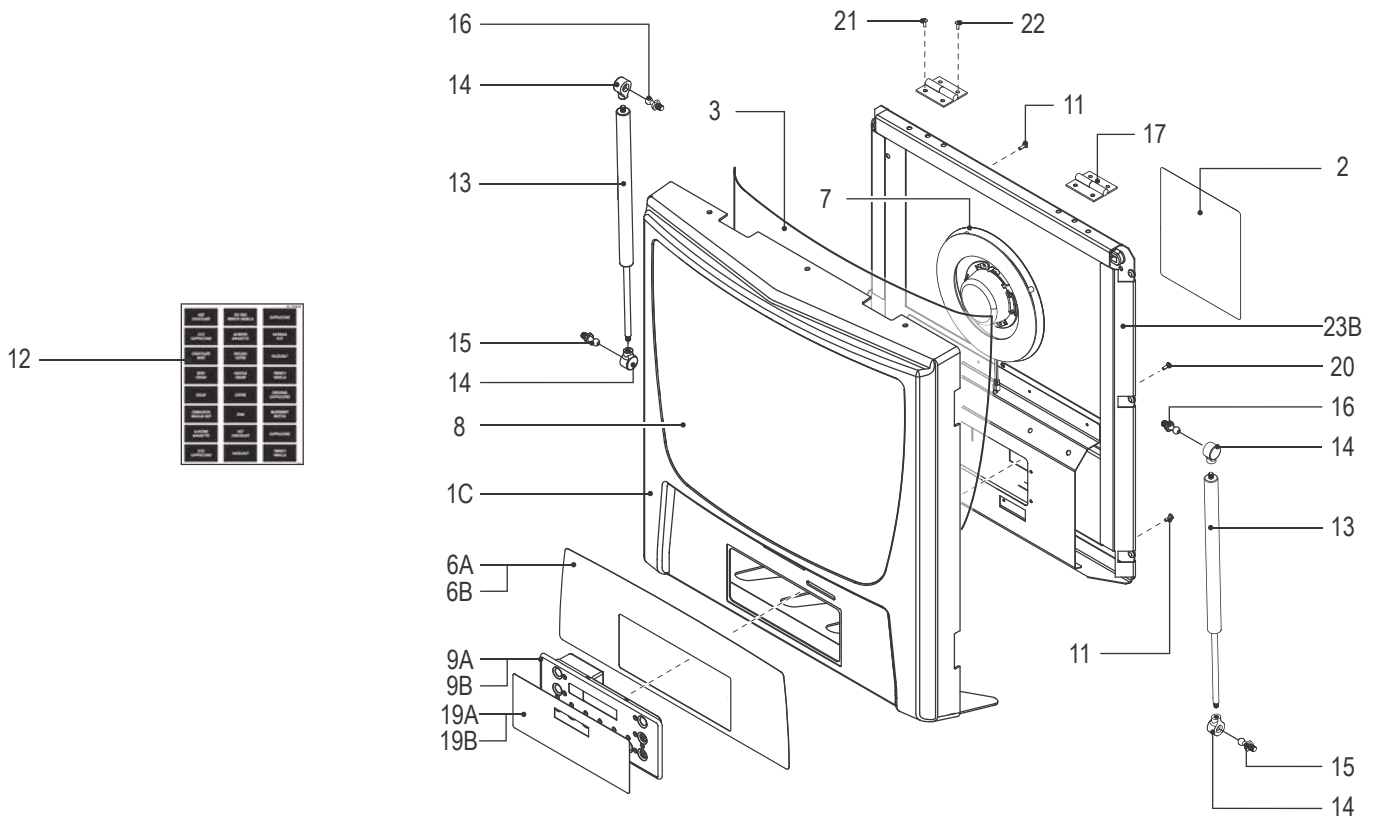

MISCELLANEOUS

PCGT4300, PCGT5300

PCGT4/5 - Door Assemblies - Parts List

ITEM #	PART #	DESCRIPTION
1A	CA-1180K ^{1,3,4,5}	KIT, DOOR ASSY PCGT4/5 (UNITS BUILT 05/01/11 AND LATER)
1B	CA-1155 ^{1,3,4,5}	DOOR, COVER PLASTIC PCGT5 (UNITS BUILT BEFORE 05/01/11)
1C	CA-1180K2 ^{2,6}	KIT, DOOR ASSY PCGT5300
1D	CA-1180K1 ⁷	KIT, DOOR ASSY PCGT5800 (UNITS BUILT 06/01/11 AND LATER)
1E	CA-1155-101 ⁷	COVER, DOOR PCGT5800 (UNITS BUILT BEFORE 06/01/11)
2	WC-39203	LABEL, SERVICING INSTRUCTIONS PC-1/2/3/4D/CK-3D/HC-1D
3	CA-1110-01	FILM, CURTIS LOGO PCGT-4/-5
4	WC-38071 ⁷	LABEL, HOT WATER TLP/PC's
5	WC-170 ⁷	SWITCH, PUSHBUTTON-RED N.O. PCGT5 HOT WATER KIT
6A	WC-39957	LABEL, MEMBRANE CONTROL PANEL PCGT4/5 CURTIS LOGO (UNITS BUILT 12/09/11 AND LATER)
6B	WC-39753	LABEL, MEMBRANE CONTROL PANEL PCGT5 (UNITS BUILT BEFORE 12/09/11)
7 [#]	CA-1176K*	KIT, LAMP ASSY LED 120V 9W CAFEPc's
8	CA-1107	WINDOW, FRONT CLEAR PCGT4/5/6 (UNITS BUILT BEFORE 5/21/18)

¹PCGT4, ²PCGT4300, ³PCGT4E, ⁴PCGT5, ⁵PCGT5DV, ⁶PCGT5300, ⁷PCGT5800

*Also replaces florescent and older style LED light assemblies used on older units.

[#]Recommended parts to stock.

[&]Complete door assemblies include the plastic front and window, but DO NOT include the UCM and light assembly.

ITEM #	PART #	DESCRIPTION
9A	WC-37127	KIT, UCM BOARD & LABEL PCGT4
9B	WC-37128	KIT, UCM BOARD & LABEL PCGT5
10	CA-1135 ^{1,3,4,5,7}	LATCH ASSY, DOOR SIDE MOUNT PCGT'S/CAFEPc'S/SD2'S
11	CA-1044 ^{2,6}	BUMPER, BUTTON BLACK
12	WC-39350-02	LABEL, PANEL FLAVOR PCGT'S CURTIS
13 [#]	WC-4932 ^{2,6}	GAS, SPRING 40LBS PCGT5300
14	WC-4933 ^{2,6}	RECEPTACLE QUICK RELEASE GAS SPRING
15	WC-4931 ^{2,6}	MOUNT, LOWER BALL STUD GAS SPRING
16	WC-4930 ^{2,6}	MOUNT, UPPER BALL STUD GAS SPRING
17	WC-4935 ^{2,6}	HINGE, ASSY DOOR PCGT5300
18	WC-13434 ^{2,6}	HARNESS DOOR EXTENSION PCGT PCGT5300 (NOT SHOWN)
19A	WC-39350-01 ^{1,2,3}	LABEL, UCM PANEL PCGT4 CURTIS
19B	WC-39351-01 ^{4,5,6,7}	LABEL, UCM PANEL PCGT5 CURTIS
20	WC-4403	SCREW, 6-32x3/8 PHIL ROUND HD
21	WC-4426	SCREW, 8-32x3/8 PH HEAD TRUSS
22	WC-4468	SCREW, 8-32x5/8 PH HD TRUSS SS
23A ^{&}	CA-1180KDC ^{1,3,4,5}	KIT, DOOR COMPLETE PCGT4/5
23B ^{&}	CA-1180K2DC ^{2,6}	KIT, DOOR COMPLETE PCGT5300
23C ^{&}	CA-1180K1DC ⁷	KIT, DOOR COMPLETE PCGT5800

PCGT4/5 - Exterior - Exploded View

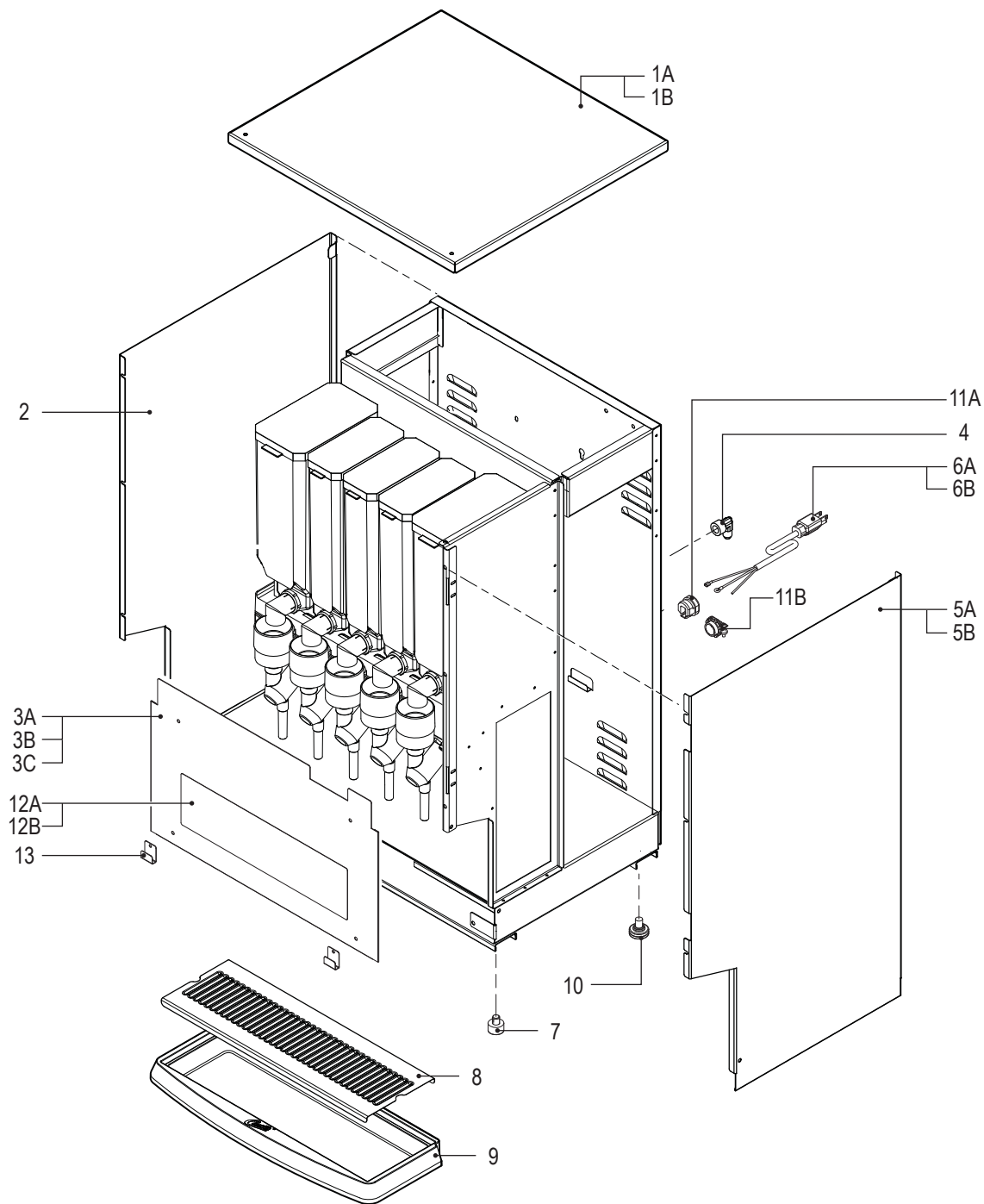

PCGT4/5 - Exterior - Parts List

ITEM #	PART #	DESCRIPTION
1A	WC-68159 ^{1,3,4,5,7}	COVER, TOP PCGT5
1B	WC-68159-101 ^{2,6}	COVER, TOP PCGT5300
2	WC-68123	PANEL, SIDE LEFT PCGT3/5
3A*	WC-68222-102K-PCGT4 ^{1,2,3}	KIT, ALCOVE PCGT4
3B*	WC-68222-102K ^{4,5,6}	KIT, ALCOVE PCGT5
3C*	WC-68222-101K ⁷	KIT, ALCOVE PCGT5800
4	WC-2401-P	ELBOW 3/8 NPT X 1/4 FLARE PLTD
5A	WC-68121 ^{1,3,4,5,7}	PANEL, SIDE RIGHT PCGT3/5
5B	WC-68121-101 ^{2,6}	PANEL, SIDE RIGHT PCGT5300
6A#	WC-1200 ^{1,2,4,5,6,7}	CORD, 14/3 SJTO 6' BLK W/PLUG
6B	WC-1231-102 ³	CORD, 2.5 mm ² 90°C 36A 450/750 V STRIPPED W/FERRULES ONE END

¹PCGT4, ²PCGT4300, ³PCGT4E, ⁴PCGT5, ⁵PCGT5DV, ⁶PCGT5300, ⁷PCGT5800

*Includes label and drip tray retainer clips. Kit also replaces older plastic alcoves which have been discontinued.

#Recommended parts to stock.

ITEM #	PART #	DESCRIPTION
7	WC-3503	LEG, 3/8"-16 STUD SCREW BUMPER
8#	WC-68147	SCREEN, DRIP TRAY PCGT5
9	CA-1157	DRIP TRAY PCGT4/5
10	WC-3518	LEG, GLIDE 3/8"-16 STUD SCREW
11A	WC-1408 ^{1,2,3,4,6,7}	CORD GRIP, 7/8" O.D.
11B	WC-1412 ⁵	CORD GRIP, 3/4" FOR METAL CORD TO .81"OD
12A	WC-390502 ^{1,2,3}	LABEL, SPLASH PANEL CUP LOCATOR PCGT4
12B	WC-390501 ^{4,5,6,7}	LABEL, SPLASH PANEL CUP LOCATOR PCGT5
13	WC-58274	RETAINER, DRIP TRAY PCGT6

PCGT4/5 - Interior Components - Exploded View

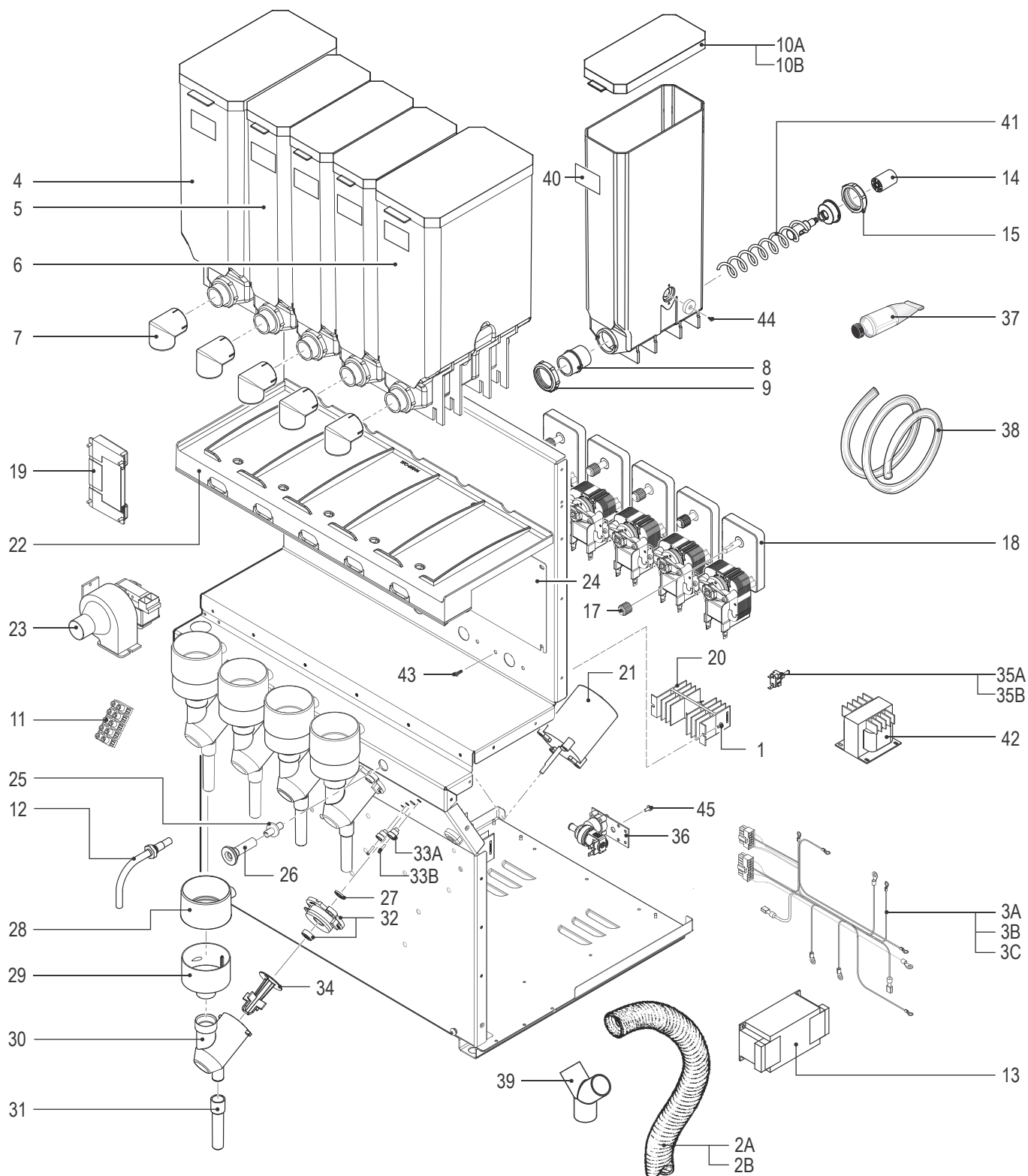

Water tanks assemblies

- See section IP76 for single voltage models
- See section IP77 for four station dual voltage models
- See section IP79 for five station dual voltage models
- See section IP80 for export models

PCGT4/5 - Interior Components - Parts List

ITEM #	PART #	DESCRIPTION
1	WC-4426	SCREW, 8-32x3/8 PH HEAD TRUSS
2A	CA-1030-17	HOSE, EXTRACTOR FAN 17" LONG ALL PC'S
2B	CA-1030-13	HOSE, EXTRACTOR FAN 13" LONG
3A	WC-13245 ^{1,2,4,6,7}	HARNESS, ASSY COMPLETE PCGT5
3B	WC-13375 ⁵	HARNESS ASSY, COMPLETE PCGT3DV PCGT4DV/PCGT5DV
3C	WC-13281 ³	HARNESS, ASSY PCGT3-31'S (INCLUDES POWER BLOCK AND POWER CABLE)
4 [#]	CA-1113-06L-P	CANISTER, ASSY 10LB LEFT PCGT'S
5 [#]	CA-1112-06-P	CANISTER, ASSY 5LB PCGT'S
6 [#]	CA-1113-06R-P	CANISTER, ASSY 10LB RIGHT PCGT'S
7	CA-1026-03-P	ELBOW, PC/CK/HC
8	CA-1065-03	BUSHING, DISCHARGE PC/CK/HC
9	WC-8539	RETAINER NUTS, PC/CK/HC
10A	CA-1002-01	LID, CANISTER 4/5LB CHAMFERED CORNERS
10B	WC-5664-05	LID, CANISTER 10LB PCGT
11	WC-314 ^{3,5}	POWER BLOCK, 5 STATION
12	WC-29602-105 ⁷	SPOUT, HOT WATER ASSY PCGT'S
13	WC-596K ³	KIT, NOISE FILTER EMI 250V/30A
14	WC-37054	KIT, SOCKET GEAR PC/CK/HC
15	WC-2626-03	BUSHING, AUGER PC/CK/HC
16	WC-13352 ⁷	HARNESS ASSY, HW KIT PCGT5 (NOT SHOWN)
17 [#]	CA-1036	GEAR, PLASTIC PC'S USE ON CA-1013
18	WC-37174	KIT, GEAR MOTOR AND GEAR PCGT
19 [#]	WC-780	CONTROL MODULE, UPM 120V PCGTs CORK BRAKE
20	WC-8556	HEATSINK, ASSY DV ALPDS/D500AP TCTD/ PTTD
21 [#]	WC-3739	KIT, MOTOR WHIPPER ASSY PC'S MOTOR SCREWS & INSTRUCTIONS
22	WC-66044	CANISTER TRAY, ASSY PLASTIC PCGT4/5
23	WC-37123	KIT, FAN EXTRACT 120V 29 CFM & BRACKET
24	WC-58120	COVER, DUMP VALVE PCGT-4/5

ITEM #	PART #	DESCRIPTION
25	CA-1095	CONNECTOR, ORIFICE WATER PLASTIC
26	CA-1011-05-P	BULKHEAD, WATER FITTING PCGT'S
27	WC-43791	RING, MOTOR SHAFT PLASTIC PC'S
28	CA-1005-03-P	STEAM TRAP, PC/CK/HC
29	CA-1009-03-P	BOWL, MIXING PC/CK/HC
30	CA-1006-06-P	CHAMBER, WHIPPER OFFSET PCGT'S
31	CA-1037-3Y-P	TUBE, EXTENSION 3.0" LONG YELLOW ALL PCGT'S
32 [#]	WC-37118	KIT, WHIPPER PLATE (3/PKG)
33A	CA-1024-05	PILLAR, LOCATION BLACK ALL PC'S
33B	WC-4440	SCREW, 8-32x 3/4" LONG PHILLIP
34	CA-1008-07K	KIT, PROPELLER WHIPPER PKG/6 OFFSET BLADES PCGT'S/CAFEPK'S
35A	WC-102 ^{1,2,4,6,7}	SWITCH, TOGGLE NON-LIT SPST 15A 125/6A 250VAC RESISTIVE
35B	WC-103 ^{3,5}	SWITCH, TOGGLE NON-LIT DPST 25A 125/250VAC RESISTIVE
36 [#]	WC-826L	VALVE, INLET 1 GPM 120V 9W
37	WC-5231	COMPOUND, HEAT SINK 5OZ
38 [#]	WC-5310	TUBE, 5/16 ID x 1/8W SILICONE GEN USE
39	WC-66049	Y-ADAPTER, EXTRACTOR FAN HOSE
40	WC-39107-02	LABEL, FLAVOR ADHESIVE CANISTR GEN USE (SET OF 40 DIFFERENT FLAVORS)
41	CA-1047	AUGER, WIRE ASSY PC'S & PCGT'S
42	WC-710 ³	TRANSFORMER,240/480 120V,500VA RU/ PCGT/CAFEPK
43	WC-4525	SCREW, 8-32x1/4PHILLIPS TRUSS HD SS
44	WC-4434	SCREW, #4 X 1/4 SS FLAT HEAD SHEET METAL FOR NEW SLIM CANIS
45	WC-4616	SCREW, 1/4-20 x 1/2 PHILLIPS PAN HEAD STAINLESS STEEL
46	WC-4440	SCREW, 8-32x 3/4" LONG PHILLIP

¹PCGT4, ²PCGT4300, ³PCGT4E, ⁴PCGT5, ⁵PCGT5DV, ⁶PCGT5300, ⁷PCGT5800

[#]Recommended parts to stock.

CANISTER CONFIGURATION			
*MODELS	10 LB. CANISTER PN CA-1113-06L-P	10 LB. CANISTER PN CA-1113-06R-P	5 LB. CANISTER PN CA-1112-06-P
PCGT4	ONE	ONE	TWO
PCGT5	ONE	ONE	THREE

WC-6294/5/6 - Tank Assembly (Standard)

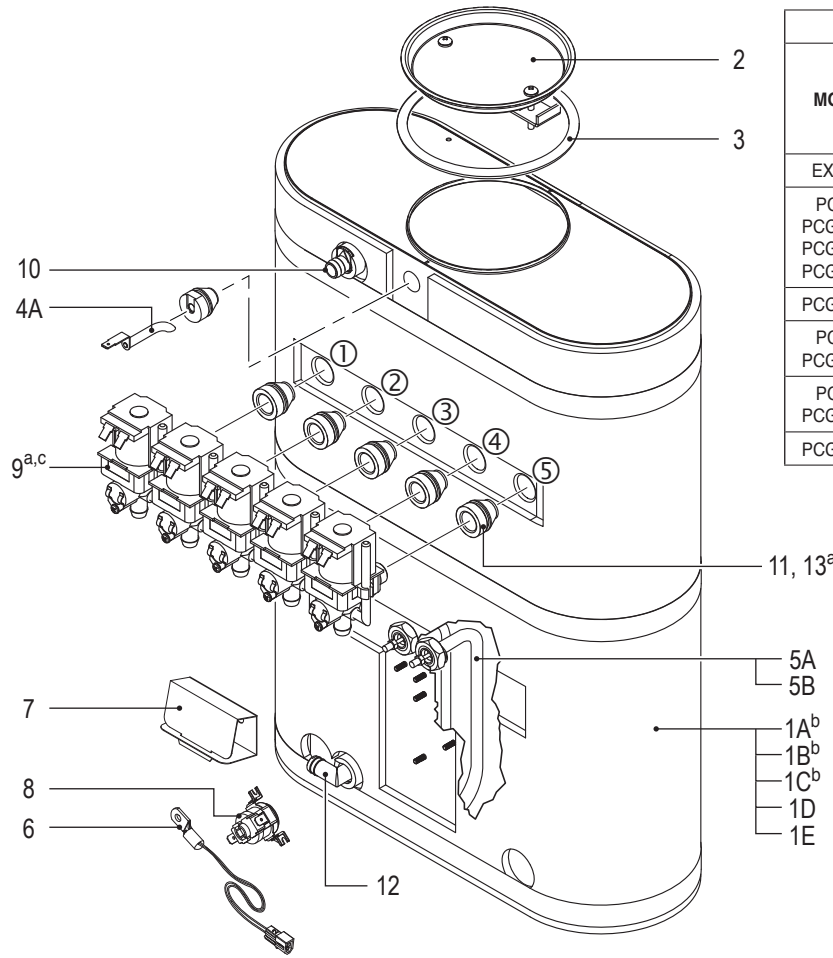

CONFIGURATION TABLE			
MODEL	ITEM 9: DUMP VALVES INSTALLED IN POSITIONS:	ITEM 11 (CONICAL BUSHING) INSTALLED IN POSITIONS:	ITEM 13 (BLIND BUSHING) INSTALLED IN POSITIONS:
EXPR10	1,3,4	1,3,4	2,5
PCGT3 PCGT3300 PCGT3700 PCGT3900	1, 2, 3	1, 2, 3	4, 5
PCGT3800	1, 2, 3, 5	1, 2, 3, 5	4
PCGT4 PCGT4300	1, 2, 3, 4	1, 2, 3, 4	5
PCGT5 PCGT5300	1, 2, 3, 4, 5	1, 2, 3, 4, 5	NA
PCGT5800	USE TANK ASSEMBLY WC-62017		

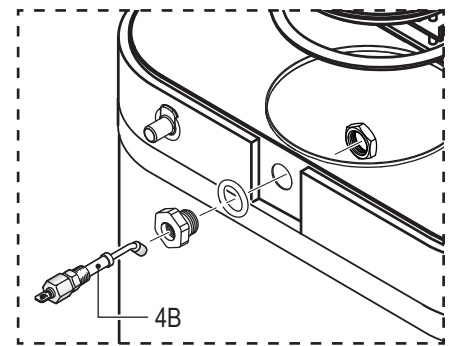

Water Level Probe Detail (Older Units)

- ^a See CONFIGURATION TABLE.
- ^b Not for use with units equipped with hot water faucet.
- ^c Valve must be calibrated when replaced. See instructions with kit.

WC-6294/5/6 - Tank Assembly - Parts List

ITEM #	PART #	DESCRIPTION
1A	WC-6294	TANK, COMPLETE PCGT3 1600W-120V W/PLSTC OVRFLW FTTN
1B	WC-6295	TANK, COMPLETE PCGT4 1600W-120V W/PLSTC OVRFLW FTTN
1C	WC-6296	TANK, COMPLETE PCGT5 1600W-120V W/PLSTC OVRFLW FTTN
1D	WC-54126	TANK, ASSY ULTEM FTTNGS PCGT'S
1E	WC-54126-10	TANK, ASSY ULTEM FTTNGS PCGT'S 1450W-120 (USED ON EXPR10)
2	WC-37008	KIT, TANK LID ROUND (INCLUDES ITEM 3)
3	WC-43067*	O-RING, 4-1/2" I.D. X Ø.285 SILICONE TANK LID
4A ¹	WC-5528K*	KIT, WATER LEVEL PROBE, SILICONE
4B ²	WC-5502-01*	KIT, PROBE, ASSY WATER LEVEL W/HEX FITTING, O-RING & NUT
5A	WC-904-04*	KIT, ELEMENT, HEATING 1.6KW/120V W/ JAM NUT & SILICONE O-RING
5B	WC-917-04*	ELEMENT, HEATING 1.45KW 120V W/JAM NUTS & SILICONE O-RING (USED ON EXPR10)

ITEM #	PART #	DESCRIPTION
6	WC-1438-101*	SENSOR, TEMPERATURE TANK
7	WC-4394*	GUARD, SHOCK/HEATING ELEMENT FOR SINGLE HEATING ELEMENT
8	WC-523*	THERMOSTAT, MANUAL RESET 120/ 240 VAC 25A 220 DEG F MAX
9	WC-880E*	VALVE, DUMP 120V 12W PC'S
10	WC-37266*	KIT, FITTING TANK OVERFLOW
11	WC-2627*	BUSHING, CONICAL .583ID X .945 OD .886LG 12mm GEN USE
12	WC-37365*	KIT, FITTING TANK INLET
13	WC-2630*	BUSHING, CONICAL BLIND GEN USE

¹ Units built 01/04/2019 and later.

² Units built before 01/04/2019.Replaces WC-5527.

* Recommended parts to stock.

WC-62111/2 - Tank Assembly (Dual Voltage)

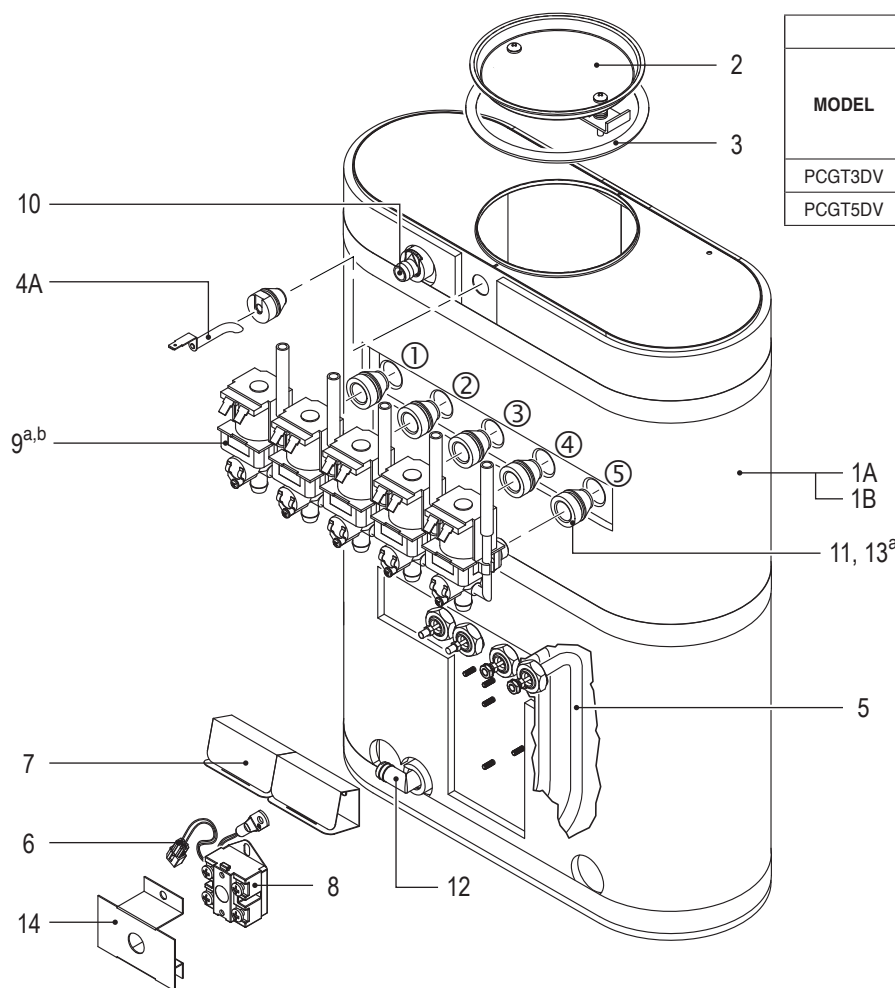

CONFIGURATION TABLE			
MODEL	ITEM 9: DUMP VALVES INSTALLED IN POSITIONS:	ITEM 11 (CONICAL BUSHING) INSTALLED IN POSITIONS:	ITEM 13 (BLIND BUSHING) INSTALLED IN POSITIONS:
PCGT3DV	1, 2, 3	1, 2, 3	4, 5
PCGT5DV	1, 2, 3, 4, 5	1, 2, 3, 4, 5	NA

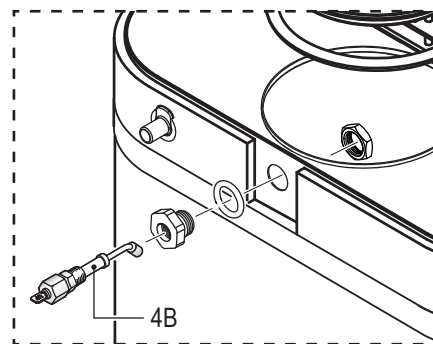

Water Level Probe Detail (Older Units)

^a See CONFIGURATION TABLE.

^b Valve must be calibrated when replaced. See instructions with kit.

WC-62111/2 - Tank Assembly - Parts List

ITEM #	PART #	DESCRIPTION
1A	WC-62111	TANK, COMPLETE PCGT3DV 1600W-120V
1B	WC-62112	TANK, COMPLETE PCGT5DV 1600W-120V
2	WC-37008	KIT, TANK LID ROUND (INCLUDES ITEM 3)
3	WC-43067*	O-RING, 4-1/2" I.D. X Ø.285 SILICONE TANK LID
4A ¹	WC-5528K*	KIT, WATER LEVEL PROBE, SILICONE
4B ²	WC-5502-01*	KIT, PROBE, ASSY WATER LEVEL W/HEX FITTING, O-RING & NUT
5	WC-904-04*	KIT,ELEMENT, HEATING 1.6KW120V W/ JAM NUT & SILICONE O-RING
6	WC-1438-101*	SENSOR, TEMPERATURE TANK
7	WC-4394*	GUARD, SHOCK/HEATING ELEMENT FOR SINGLE HEATING ELEMENT

ITEM #	PART #	DESCRIPTION
8	WC-522*	THERMOSTAT, HI LIMIT HEATER CONTROL DPST 277V 40A
9	WC-880E*	VALVE, DUMP 120V 12W PC'S
10	WC-37266*	KIT, FITTING TANK OVERFLOW
11	WC-2627*	BUSHING, CONICAL .583ID X .945 OD .886LG 12mm GEN USE
12	WC-37365*	KIT, FITTING TANK INLET
13	WC-2630*	BUSHING, CONICAL BLIND GEN USE
14	WC-43055*	GUARD, SHOCK RESET THERMOSTAT (WC-522)

¹ Units built 01/04/2019 and later.

² Units built before 01/04/2019.Replaces WC-5527.

* Recommended parts to stock.

WC-62017 - Tank Assembly

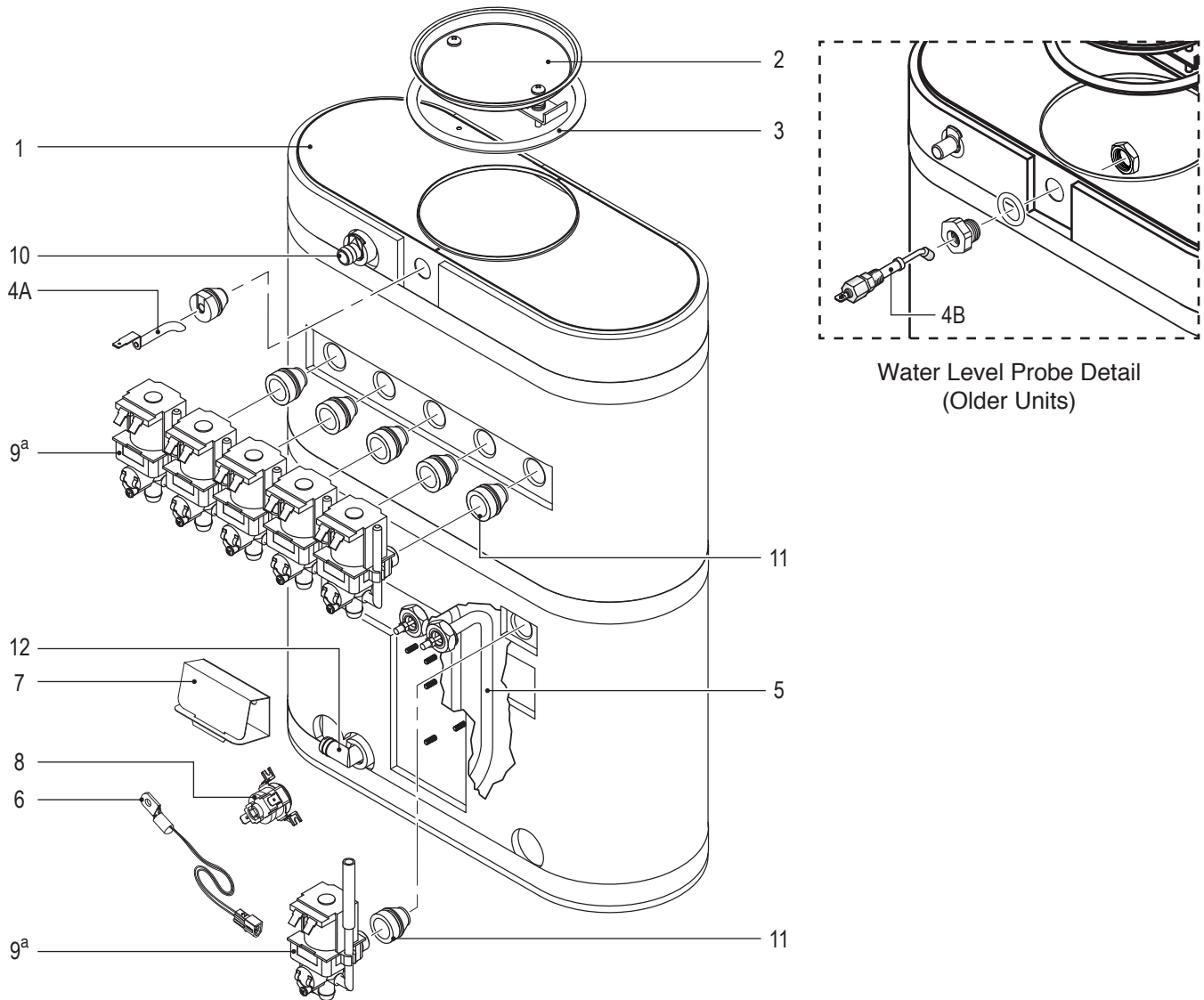

^a Valve must be calibrated when replaced. See instructions with kit.

WC-62017 - Tank Assembly - Parts List

ITEM #	PART #	DESCRIPTION
1	WC-62017	TANK, COMPLETE HEATING 1600W-120V FOR UNITS WITH HW PCGT5
2	WC-37008	KIT, TANK LID ROUND (INCLUDES ITEM 3)
3	WC-43067*	O-RING, 4-1/2" I.D. X Ø.285 SILICONE TANK LID
4A ¹	WC-5528K*	KIT, WATER LEVEL PROBE, SILICONE
4B ²	WC-5502-01*	KIT, PROBE, ASSY WATER LEVEL W/HEX FITTING, O-RING & NUT
5	WC-904-04*	KIT, ELEMENT, HEATING 1.6KW120V W/ JAM NUT & SILICONE O-RING
6	WC-1438-101*	SENSOR, TEMPERATURE TANK

ITEM #	PART #	DESCRIPTION
7	WC-4394*	GUARD, SHOCK/HEATING ELEMENT FOR SINGLE HEATING ELEMENT
8	WC-523*	THERMOSTAT, MANUAL RESET 120/ 240 VAC 25A 220 DEG F MAX
9	WC-880E*	VALVE, DUMP 120V 12W PC'S
10	WC-37266*	KIT, FITTING TANK OVERFLOW
11	WC-2627*	BUSHING, CONICAL .583ID X .945 OD .886LG 12mm GEN USE
12	WC-37365*	KIT, FITTING TANK INLET

¹ Units built 01/04/2019 and later.

² Units built before 01/04/2019. Replaces WC-5527.

* Recommended parts to stock.

WC-54126-31 - Tank Assembly (Export)

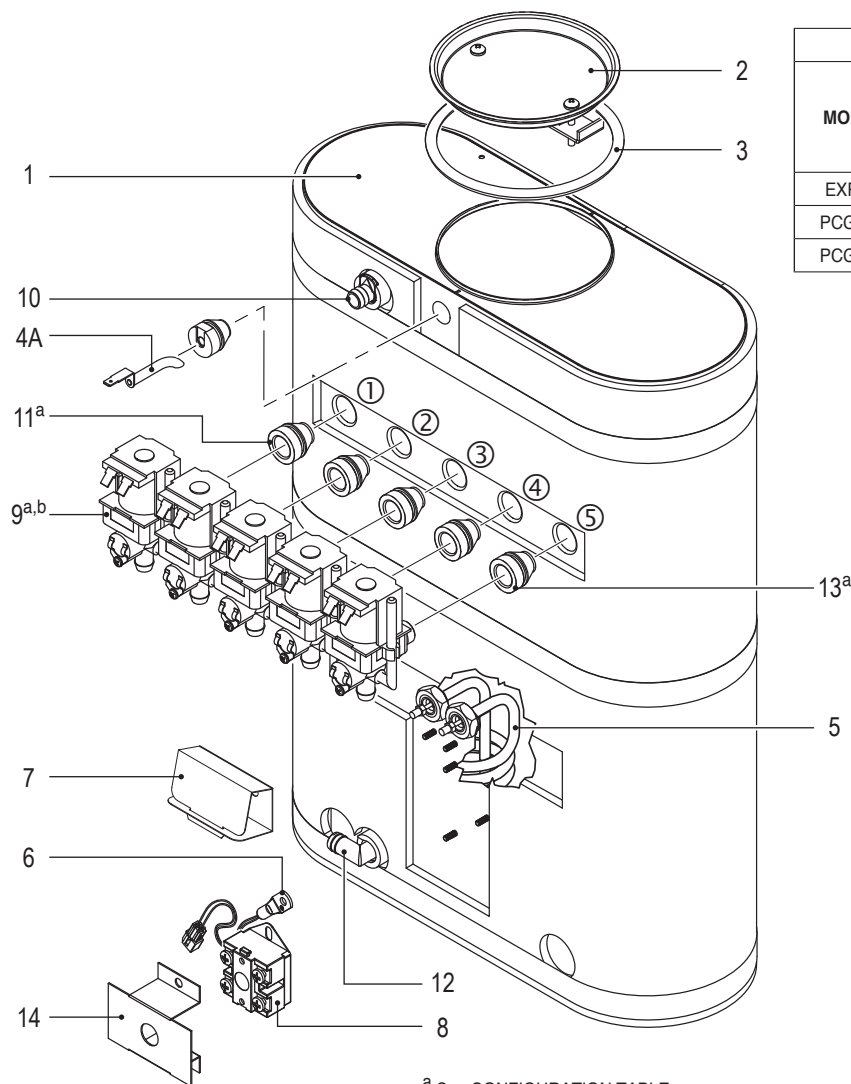

CONFIGURATION TABLE			
MODEL	ITEM 9: DUMP VALVES INSTALLED IN POSITIONS:	ITEM 11 (CONICAL BUSHING) INSTALLED IN POSITIONS:	ITEM 13 (BLIND BUSHING) INSTALLED IN POSITIONS:
EXPRE	1,3,4	1,3,4	2,5
PCGT3E	1, 2, 3	1, 2, 3	4, 5
PCGT4E	1, 2, 3, 4	1, 2, 3, 4	5

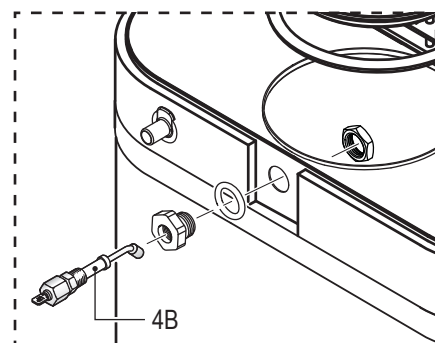

Water Level Probe Detail (Older Units)

^a See CONFIGURATION TABLE.
^b Valve must be calibrated when replaced. See instructions with kit.

WC-54126-31 - Tank Assembly - Parts List

ITEM #	PART #	DESCRIPTION
1	WC-54126-31	TANK, ASSY ULTEM FTTNGS PCGT'S EXPORT UNITS
2	WC-37008	KIT, TANK LID ROUND (INCLUDES ITEM 3)
3	WC-43067*	O-RING, 4-1/2" I.D. X Ø.285 SILICONE TANK LID
4A ¹	WC-5528K*	KIT, WATER LEVEL PROBE, SILICONE
4B ²	WC-5502-01*	KIT, PROBE, ASSY WATER LEVEL W/HEX FITTING, O-RING & NUT
5	WC-922-04*	KIT, ELEMENT HEATING 3.5KW 220V W/JAM NUTS & SILICONE WASHERS
6	WC-1438-101*	SENSOR, TEMPERATURE TANK
7	WC-4394*	GUARD, SHOCK/HEATING ELEMENT FOR SINGLE HEATING ELEMENT

ITEM #	PART #	DESCRIPTION
8	WC-522*	THERMOSTAT, HI LIMIT HEATER CONTROL DPST 277V 40A
9	WC-880E*	VALVE, DUMP 120V 12W PC'S
10	WC-37266*	KIT, FITTING TANK OVERFLOW
11	WC-2627*	BUSHING, CONICAL .583ID X .945 OD .886LG 12mm GEN USE
12	WC-37365*	KIT, FITTING TANK INLET
13	WC-2630*	BUSHING, CONICAL BLIND GEN USE
14	WC-43055*	GUARD, SHOCK RESET THERMOSTAT (WC-522)

¹ Units built 01/04/2019 and later.

² Units built before 01/04/2019. Replaces WC-5527.

* Recommended parts to stock.

Domestic, 4 Station Models

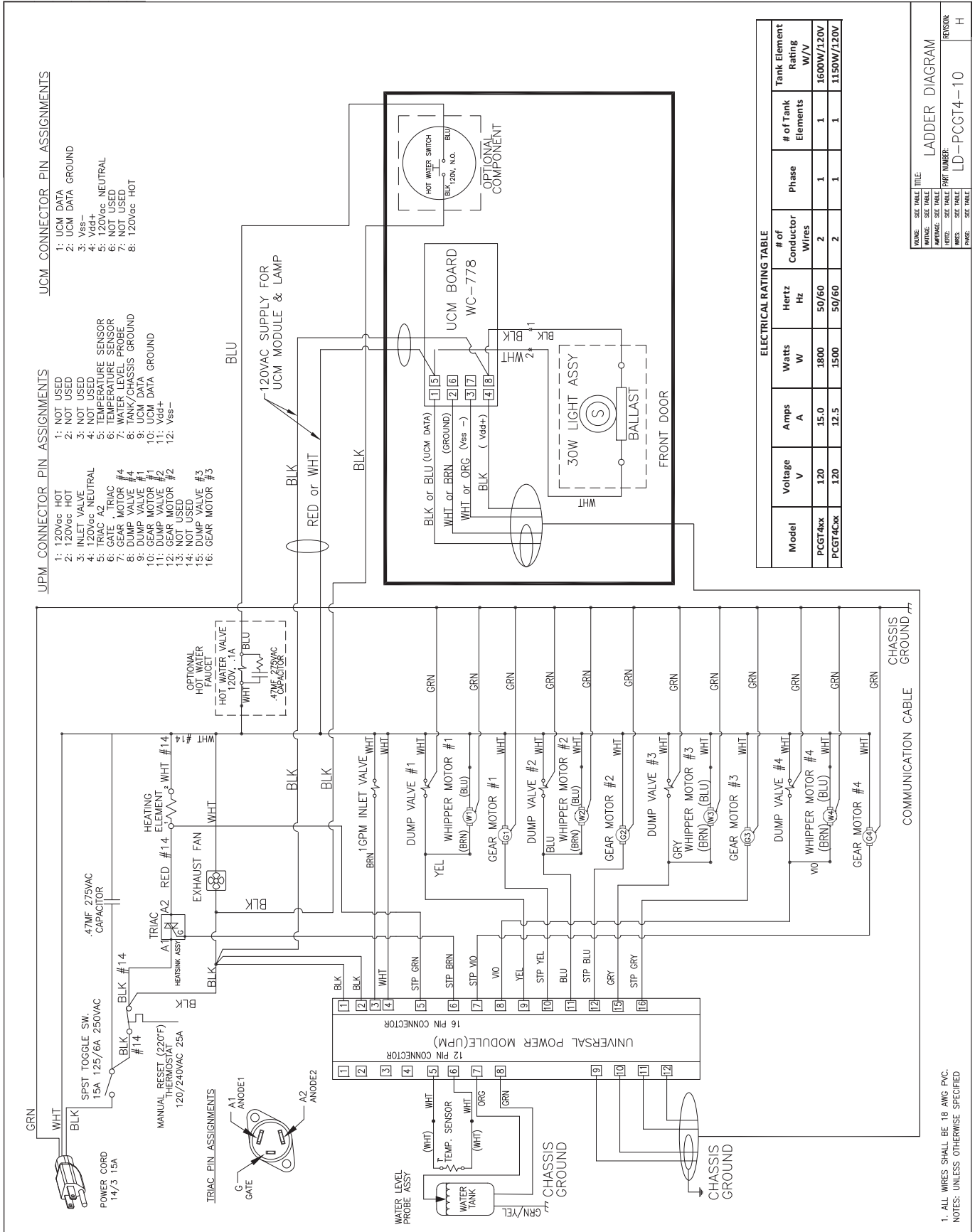

Export, 4 Station Models

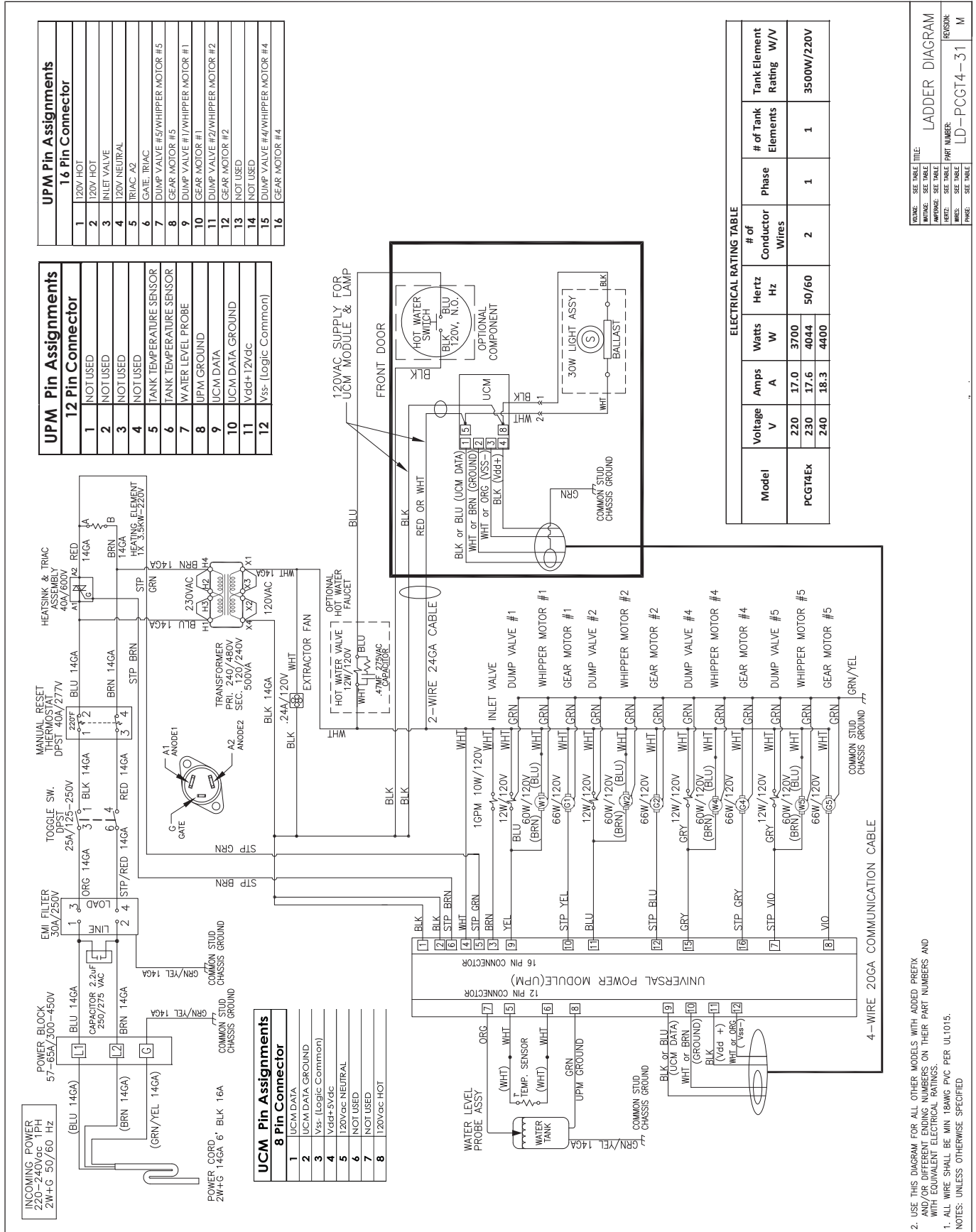

5 Station, Single Voltage Models

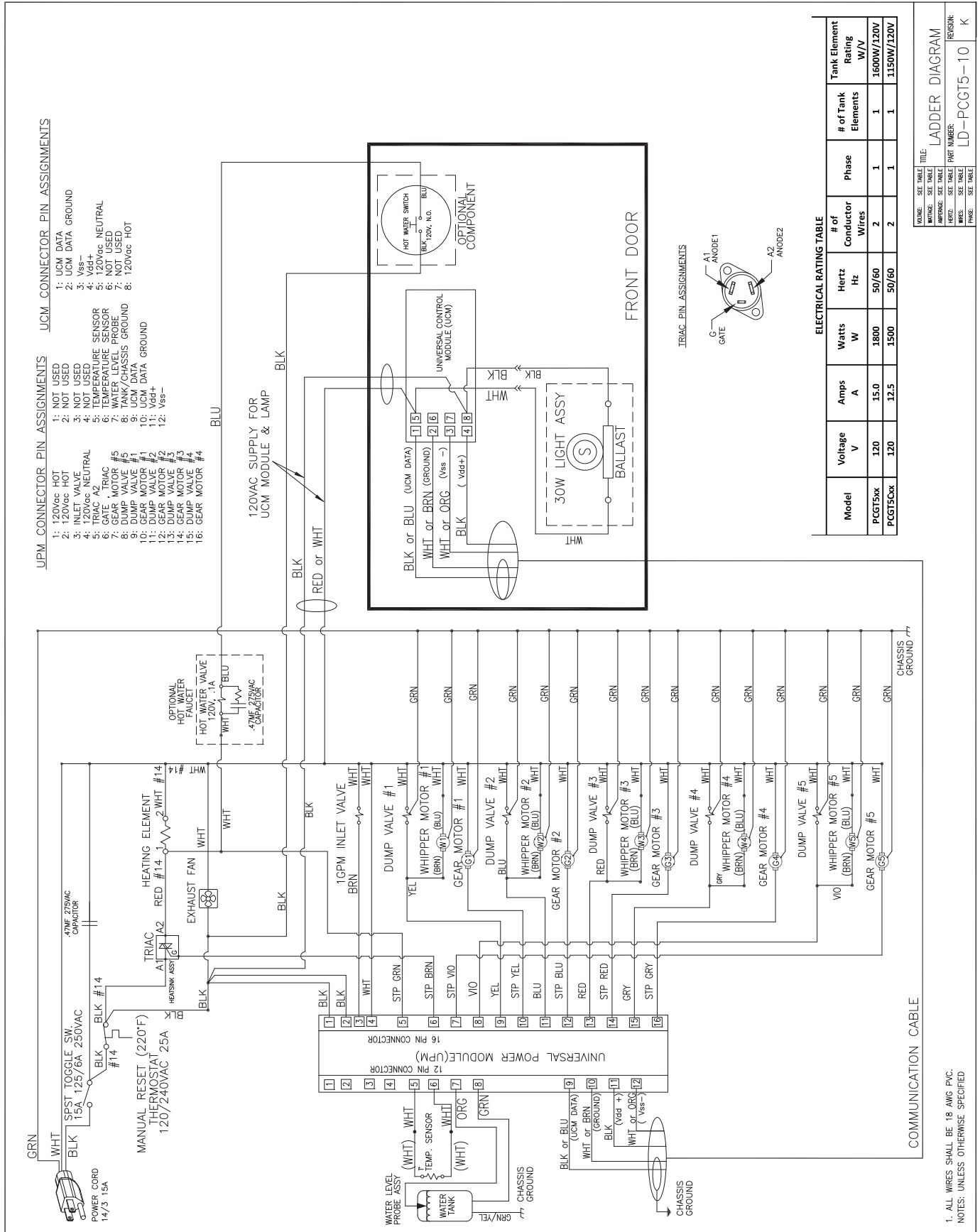

5 Station, Dual Voltage Models

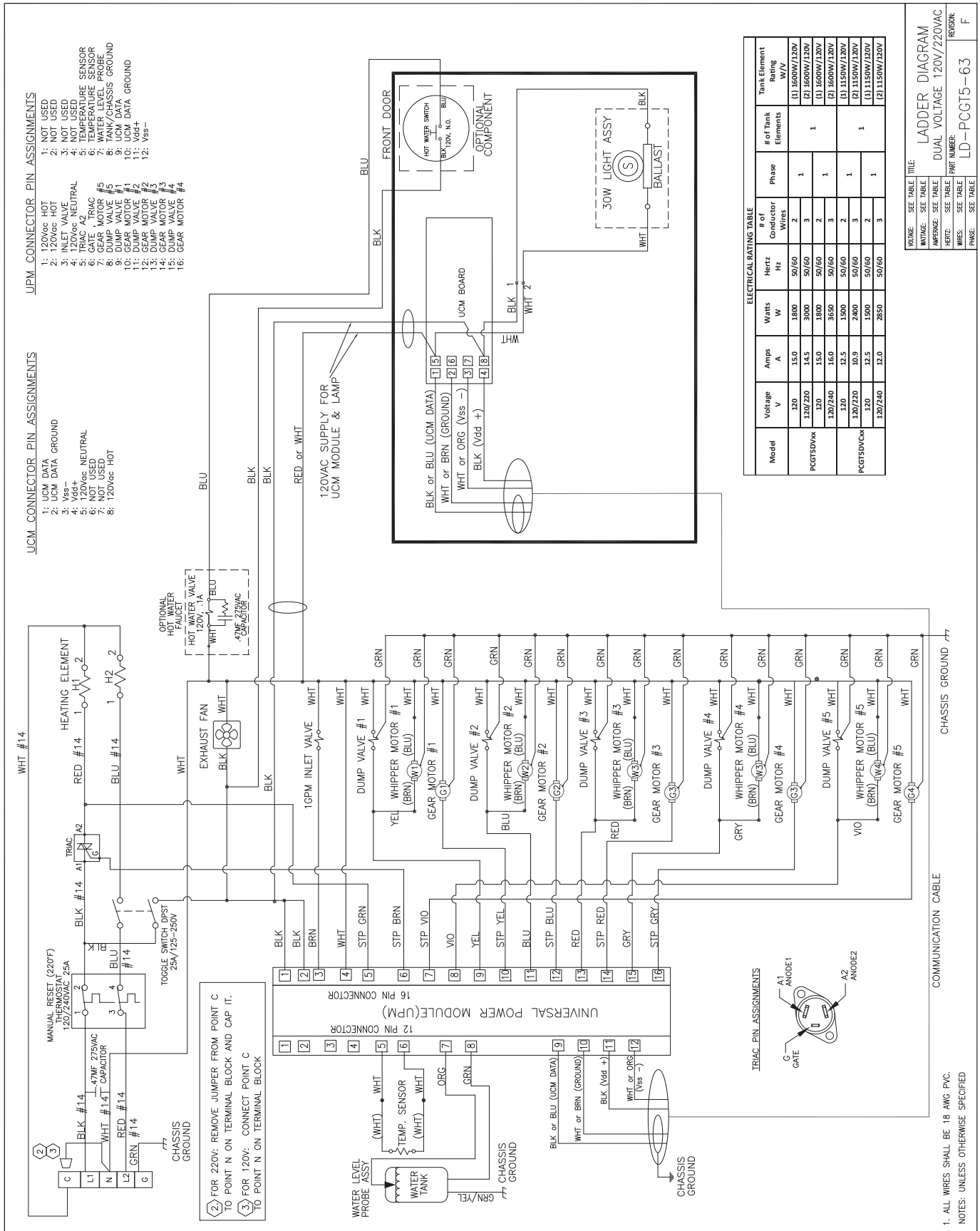

**WARNING:**

Electric Shock Hazard - the following procedures are to be performed only by a qualified service technician. Disconnect power when replacing components. Neither Wilbur Curtis Co., Inc. nor the seller can be held responsible for the interpretation of this information, or any liability in connection with its use.

Scald and Burn Hazard - keep body parts clear of hot surfaces during troubleshooting.



IMPORTANT: If it is necessary to replace the universal power module (UPM), always check all inlet and dump valve coils for a short and replace the valve as necessary, before replacing the module. See the **Valve Test Procedure**, below to test for defective valves.

Troubleshooting Guidelines

- If an error message appears on the display, consult the **ERROR CODES** section before troubleshooting.
- A dispenser that is not level may not function properly. Make sure the unit is properly leveled before proceeding.
- This troubleshooting guide identifies some, but not all, of the possible causes for common problems that can occur.
- Use this troubleshooting guide along with the appropriate **ELECTRICAL SCHEMATIC**.

Valve Test Procedure

Use a digital multi-meter to measure the resistance of valve coils.

Measure the resistance across the valve coil terminals with the wiring harness disconnected. Reverse the meter leads on the terminals and measure the resistance in the opposite direction. A resistance of less than 100 ohms, in either direction, indicates a shorted coil. The valve must be replaced.

If a shorted coil is not detected, test for an open coil:

- 1 Reconnect the valve terminals to the wiring harness.
- 2 Power up the dispenser with the appropriate cover(s) removed to allow access to the valve.
- 3 Run a dispense cycle while monitoring the voltage at the valve coil terminals. If voltage is present on the terminals, you should hear the valve click open/closed at the moment power is applied or removed from the terminals. The inlet valve should open any time the water tank is not full. If the valve does not open, replace the valve. If voltage is not detected, first check the wiring. If the wiring is OK, replace the UPM.

Water Not Hot Enough

- 1 If the water heats, but is not hot enough, first check for the correct temperature setting on the control panel. Reprogram as necessary.
- 2 If the temperature setting is OK, but the actual water temperature does not match the setting on the control panel, replace the temperature sensor.

Water Heats More Slowly Than Usual

- 1 Check for power across the terminals of the heating element(s). If power is being supplied, disconnect the heating element(s) and check for continuity. Replace a heating element if the resistance is too high (nominal resistance is 13 Ohms).
- 2 If there is no power to the heating element(s), check the wiring to any element that does not have the proper voltage across it. Also check for corroded connections anywhere between the power cord and the heating element(s).

Water Does Not Heat At All

- Check to see if the water level in the tank is in contact with the water level probe. If not, see *Tank Does Not Fill*. The water will not heat unless it is in contact with the probe.
- If the water heats, but is not hot enough, see *Water Not Hot Enough*.
- If **Ready to Dispens** appears on the display, but the water is not hot, check the resistance across the leads of the temperature sensor. If the resistance is less than 10 k and the water is not hot, replace the temperature sensor. If the sensor resistance is above 10 k when the water is cool, replace the universal power module (UPM).

If **Heating...** appears on the display, but the water is not hot, follow the steps below. The following steps are performed with the rear toggle switch in the ON position.

- 1 Check for power across the terminals of the heating element(s). If power is being supplied, remove the wires and check for an open heating element.
- 2 If there is no power to the element(s), trace the circuit back (using the *ELECTRICAL SCHEMATIC*) to the power cord to find out where power is lost. If there is power into the triac but not out, see the following step.
- 3 If there is power into a triac, but not out, check for power at the gate terminal. If the connections are good and power is being supplied to the triac, but there is no voltage out of A2, replace the triac. If power is not being supplied from the UPM, but **Heating...** appears on the display, check the wiring from the UPM to the triac. If the wiring is OK, replace the UPM.

Water Too Hot (Boiling or Excessive Steaming)



IMPORTANT: If the unit is being operated at elevations above 2000 feet (600 m), before proceeding, make sure that the control panel temperature is set to the factory default setting of 190°F (88°C). The boiling point of water goes down with increases in elevation.

- 1 If **Over Temp Sensor** or **Ready to Dispens** appears on the display and the water is too hot, go to *Over Temp Sensor Error Message*.
- 2 If the display reads **Heating...** constantly, first check to make sure that the temperature sensor is attached tightly to the tank and that heat sink compound was used. A properly mounted sensor should have a resistance of around 7 k when the water is hot. If not, replace the sensor.
- 3 Check to see if the universal power module (UPM) constantly has power output to the triac, regardless of the resistance of the temperature sensor. If so, the UPM is probably bad.
- 4 If the UPM is working properly, check for a bad triac.

Sensor Error Message

This error indicates a malfunction (open circuit) in the temperature sensor system. Once the malfunction is corrected, the error message must be cleared. To reset the dispenser and return to normal operation, turn the toggle switch on the back of the unit to the OFF position for 5 seconds, then back ON.

- 1 Check the resistance across the leads of the temperature sensor while it is disconnected from the universal power module (UPM). If an open circuit is measured (resistance above 200 k), replace the sensor.
- 2 If the sensor resistance is less than 200 k check the sensor wires for corrosion and reconnect them to the UPM. Afterward, if the error message comes back after resetting the control and power modules, replace the UPM.

No Power - Display Not Lit

- 1 Make sure the circuit breaker to the circuit supplying power to the unit is not tripped and is turned on.
- 2 On dispensers with a power plug, make sure it is connected to the power receptacle.
- 3 Make sure that the main power toggle switch on the back panel is turned ON.
- 4 Verify that all wires from the power cord are properly connected inside the unit. Loose connections can create heat. Check to make sure the wires are not burned/overheated. Check chassis ground.
- 5 Check to make sure power and ground are being supplied to the universal control module (UCM). If there is power into the UCM, but the display is blank, the UCM is probably bad.
- 6 If there is no power into the UCM, trace the circuit back (using the wiring diagram) to the power cord to find out where power is lost. If there is power into the thermostat reset switch, but not out, see step 7.
- 7 If there is power into the thermostat reset switch, but not out, check to make sure that the water tank is not empty. If the tank is empty, the reset switch has probably opened up due to a low water level, go to **Water Tank Does Not Fill**. If there is water in the tank, but no power out, push in on the reset switch button to see if it restores power. If power is restored, check to make sure that the switch is not opening up at the wrong temperature (the switch should not open up at normal operating water temperatures). If there is still no power through the switch after pushing the button, replace the thermostat reset switch.

Water Tank Overfills

- 1 Turn the toggle switch on the back of the unit ON and OFF. If water continues to flow when the switch is in both positions, replace the inlet valve.
- 2 If water stops flowing to the water tank when the toggle switch is turned OFF and continues when the switch is turned back ON, remove the orange wire from the water probe on the tank. While power is ON, short the end of the orange wire to the metal surface on the outside of the tank. If the water tank stops filling when the orange wire is shorted to the tank, check for a corroded connection at the water probe.
- 3 If water does not stop flowing when the orange wire is shorted to the tank, check the tank ground connection and the continuity of the orange wire connecting to the universal power module (UPM). If both are OK, replace the UPM.

Water Tank Does Not Fill



IMPORTANT: No water or low water in the tank can cause the tank to overheat, resulting in the thermostat reset switch opening. If after correcting a tank fill problem there is no power to the control panel, push the reset switch button.

- 1 Check to make sure the water supply is turned on. Check for a plugged water supply line, clogged water filter or plugged inlet valve.
- 2 If there are no plugs in the water supply line, check for power across the inlet valve terminals. If power is being supplied, but there is no water flow, replace the inlet valve.
- 3 If power is not being supplied to the inlet valve, check the wires between the universal power module (UPM) and the inlet valve. Check for corroded connections.
- 4 If the wiring between the UPM and the inlet valve is OK, but there is no power to the inlet valve, remove the orange wire from the water tank probe. If the water tank starts to fill, replace the water probe. If the water tank does not start to fill, replace the UPM.

Water Level Error Message

Water level fill error or overflow. This error message occurs when the inlet valve solenoid has been on too long during initial fill or tank refill, See the **ERROR CODES** section for the maximum times allowed. Once the malfunction is corrected, the error message must be cleared. To reset the unit and return to normal operation, turn the toggle switch on the back of the unit to the OFF position for 5 seconds, then back ON, or press and hold the  button on the control panel .

- 1 Check to make sure that the flow rate from the water supply line meets the minimum flow rate specifications for the dispenser. Also check the water pressure. See the **SPECIFICATIONS** section.
- 2 Check for blockage at the inlet valve inlet or outlet. Check for blockage in the tubing between the inlet valve and the water tank.
- 3 Check the water probe wire for an open condition or corroded connections.
- 4 If the probe connections are OK, cycle power to the unit by turning the rear toggle switch OFF, then ON. Check to see if power is applied to the inlet valve terminals. If power is applied to the terminals, but there is no water flow, replace the inlet valve.
- 5 Check for power from the universal power module (UPM) to the inlet valve. If the wiring is OK, replace the UPM.

Water Flows From Dispenser Spout Constantly

- 1 Check to see if water continues to flow from the spout when the toggle switch is turned OFF. Replace any valve that is stuck open.
- 2 If one or more of the valves mentioned in step 1 turns on when the toggle switch on the back is ON and turns off when the switch is OFF, replace the universal power module (UPM).

No Water Flows From the Spout While “Dispensing...” Appears on the Display

Condition: Whipper motor runs and powder comes out of the spout, but no water:

- 1 Check to see if power is being supplied to the associated dump valve when the dispense button is pushed. If power is being supplied, but there is no water flow, replace the valve.
- 2 If power is not being supplied to the dump valve during the dispense cycle, first check the wiring from the universal power module (UPM) to the valve.
- 3 If the wiring is OK, check for power output from the UPM while the dispense button is being pushed. Replace the UPM if there is no power out.

Cup Not Filled To Normal Level During Dispensing or Overflows (Preset Dispense Models Only)

Check to make sure that the universal control module (UCM) Dispense by Time setting is correct. See **PROGRAMMING GUIDE** section.

Only Water is Dispensed

Condition: Water flows and whipper motor runs, but NO powder is dispensed:

- 1 Check to see if the canister is empty.
- 2 Check to see if the powder is damp, which will inhibit powder flow. Moisture build up inside the canister is usually due to an exhaust fan not working. Check to make sure that the fan is getting power and/or that the fan is turning.
- 3 Check to make sure that the Powder % Ratio is not set to 0%. See the **PROGRAMMING GUIDE** section.
- 4 Remove the canister. Push the dispense button and check to make sure that the canister gear at the back of the compartment is turning. If it is, check for a stripped gear on both the canister and on the gear motor shaft. If the gears are OK, check the canister auger assembly.

Product Dispensed Into Cup is Weak



IMPORTANT: Dump valves should NOT be field adjusted to change product strength. Product strength adjustments should be done through programming on the front panel only.

Condition: Water flows and whipper motor runs, but amount of powder flow is too low:

- 1 Check to see if the canister is full.
- 2 Check to see if the powder is damp, which will inhibit powder flow. Moisture build up inside the canister is usually due to an exhaust fan not working. Check to make sure that the fan is getting power and/or that the fan is turning.
- 3 Check to make sure that the Powder % Ratio is properly set. See the *PROGRAMMING GUIDE* section.
- 4 Check for a stripped gear on both the canister and on the gear motor shaft. If the gears are OK, check the canister.

Whipper Motor Does Not Run During Dispensing

Condition: Whipper motor does not run, but water and powder are flowing when the dispense button is pushed:

- 1 Check to see if power is being supplied to the associated whipper motor when the dispense button is pushed. If power is being supplied, but the motor does not run, replace the motor.
- 2 If power is not being supplied to the whipper motor during the dispense cycle, first check the wiring from the universal power module (UPM) to the motor.
- 3 If the wiring is OK, check for power output from the UPM while the dispense button is being pressed. Replace the UPM if there is no power out.

Dispenser Does Not Respond (at all) When Dispense Button is Pushed

- 1 If **Dispensing...** appears on the display, check for faulty wiring and connections between the universal control module (UCM) and the universal power module (UPM). If the wiring is OK, but NOTHING happens when **Dispensing...** appears on the display, suspect the UCM or the UPM.
- 2 If **Dispensing...** does not appear on the display, check for a faulty membrane panel or smart membrane encoder (if applicable). Then, check for a bad universal control module (UCM).

Dispenser Overflows During Dispensing

Manual dispense models: Make sure to release the dispense button when the cup is 3/4 full.

Preset dispense models: Check the Dispense by Time setting. See the *PROGRAMMING GUIDE* section.

Front Panel Light Not Working

- 1 Units with tubular shaped LED light: With the power switch on, check for 120 Vac into the light power supply and 36 Vdc out. Check for 36 Vdc to the light fixture. If power is being supplied to the light but does not come on, replace the light assembly.
- 2 Units with florescent or new style LED light assembly*: Check to make sure power is being supplied to the light fixture (power switch on back of unit must be on). If power is being supplied to the light but it does not come on, replace the light assembly.

*See diagram in *ILLUSTRATED PARTS LIST*.

Dump Valve Calibration

After installing a new dump valve, do not reinstall the dump valve cover and canisters, so that you can perform the calibration steps below:

- 1 Turn the toggle switch on the back of the unit to the ON position. Wait for the ready light to come on.
- 2 Place a measuring cup below the spout connected to the dump valve that was replaced.
- 3 Push the DISPENSE button for the spout connected to the dump valve that was replaced. Time the flow rate.* Water should flow at a rate of 7 oz. (8 oz. Max) in 10 seconds. If the flow rate is OK, skip to step 6. If the flow rate is too high or too low, perform the steps that follow.
- 4 Open the door on the front of the unit. Using a 6 mm hex wrench, turn the adjustment screw on the front of the valve one half turn. Turn counterclockwise to increase the flow rate or clockwise to decrease.
- 5 Close the door and recheck the flow rate. If the flow rate is 7 oz. (8 oz. Max) in 10 seconds, replace the dump valve cover and canisters. If the flow rate is still out of calibration, repeat steps 4 and 5 until the flow rate is correct.
- 6 Replace the dump valve cover and canisters when the flow rate is correct to return the unit to normal use.

*All PCGT series units, except Pre-Set Dispense models, are equipped with a valve calibration feature that dispenses water for 10 seconds, eliminating the need for manual timing. See the *Programming Guide* section.

System Fault Messages

An error message will appear on the screen in the event of a malfunction under the following conditions:

- 1 Water level overflow. This error indicates that either there is not enough incoming water flow/pressure or a water overflow condition (unit will stop functioning).
- 2 Break in temperature control circuit.
- 3 Break in control board communication circuit.

If any of the errors below appear on the screen, turn off the main power toggle switch and call for service.

ERROR MESSAGE	WARNING DESCRIPTION	CAUSE
Water Level Error 1-(800)-000-0000	Fill run error/Overflow	The water inlet valve has either been open for more than 10 minutes on the initial tank fill or has been open for more than 1 1/2 minutes in normal operation.
Sensor Error 1-(800)-000-0000	Open Probe	Break in the temperature thermistor circuit.
Communication Error	Communication error between the UCM and the universal power module	Break in the communication wires between the two control boards.

Wilbur Curtis Co., Inc. certifies that its products are free from defects in material and workmanship under normal use. The following limited warranties and conditions apply:

- 3 years, parts and labor, from original date of purchase on digital control boards
- 2 years, parts, from original date of purchase on all other electrical components, fittings and tubing
- 1 year, labor, from original date of purchase on all other electrical components, fittings and tubing

Additionally, Wilbur Curtis Co., Inc. warrants its grinding burrs for forty (40) months from the date of purchase or 40,000 pounds of coffee, whichever comes first. Stainless steel components are warranted for two (2) years from the date of purchase against leaking or pitting. Replacement parts are warranted for ninety (90) days from the date of purchase or for the remainder of the limited warranty period of the equipment in which the component is installed.

All in-warranty service calls must have prior authorization. For authorization, call the Technical Support Department at 800-995-0417. Additional conditions may apply. Go to www.wilburcurtis.com to view the full product warranty information.

CONDITIONS & EXCEPTIONS

The warranty covers original equipment at time of purchase only. Wilbur Curtis Co., Inc., assumes no responsibility for substitute replacement parts installed on Curtis equipment that have not been purchased from Wilbur Curtis Co., Inc. Wilbur Curtis Co., Inc. will not accept any responsibility if the following conditions are not met. The warranty does not cover:

- **Adjustments and cleaning:** *The resetting of safety thermostats and circuit breakers, programming and temperature adjustments are the responsibility of the equipment owner. The owner is responsible for proper cleaning and regular maintenance of this equipment.*
- **Replacement of items subject to normal use and wear:** *This shall include, but is not limited to, spray heads, faucets, light bulbs, shear disks, "O" rings, gaskets, silicone tubing, silicone elbows, canister assemblies, whipper chambers and plates, mixing bowls, agitation assemblies and whipper propellers.*

The warranty is void under the following circumstances:

- **Improper operation of equipment:** *The equipment must be used for its designed and intended purpose and function.*
- **Improper installation of equipment:** *This equipment must be installed by a professional technician and must comply with all local electrical, mechanical and plumbing codes.*
- **Improper voltage:** *Equipment must be installed at the voltage stated on the serial plate supplied with this equipment.*
- **Improper water supply:** *This includes, but is not limited to, excessive or low water pressure and inadequate or fluctuating water flow rate.*
- **Damaged in transit:** *Equipment damaged in transit is the responsibility of the freight company and a claim should be made with the carrier.*
- **Abuse or neglect (including failure to periodically clean or remove lime accumulations):** *The manufacturer is not responsible for variation in equipment operation due to excessive lime or local water conditions. The equipment must be maintained according to the manufacturer's recommendations.*

Repairs and/or Replacements are subject to Curtis' decision that the workmanship or parts were faulty and the defects showed up under normal use. All labor shall be performed during regular working hours. Overtime charges are the responsibility of the owner. Charges incurred by delays, waiting time, or operating restrictions that hinder the service technician's ability to perform service is the responsibility of the owner of the equipment. This includes institutional and correctional facilities. Wilbur Curtis Co., Inc. will allow up to 100 miles, round trip, per in-warranty service call.

Return Merchandise Authorization (RMA): All claims under this warranty must be submitted to the Wilbur Curtis Technical Support Department prior to performing any repair work or return of this equipment to the factory. **All returned equipment must be properly re-packaged in the original carton and received by Curtis within 45 days following the issuance of a RMA.** No units will be accepted if they are damaged in transit due to improper packaging. **NO UNITS OR PARTS WILL BE ACCEPTED WITHOUT A RETURN MERCHANDISE AUTHORIZATION (RMA). THE RMA NUMBER MUST BE MARKED ON THE CARTON OR SHIPPING LABEL. All warranty claims must be submitted within 60 days of service. Invoices will not be processed or accepted without a RMA number. Any defective parts must be returned in order for warranty invoices to be processed and approved.** All in-warranty service calls must be performed by an authorized service agent. Call the Wilbur Curtis Technical Support Department to find an agent near you.